

Showermate Standard Twin Pumps

There's nothing more irritating than a tap or a shower that's no more than a trickle. Thankfully, the new Showermate from Stuart Turner means it's a problem you need never worry about again. Not only will Showermate give your water pressure a much needed boost.

They can be used for:

- Bath/basin mixer tap.
- Fixed plate or single function shower.
- Multi-function shower.
- 2 x multi-function showers.
- Multi-function shower with two body jets.

Designed to suit any tank fed, open vented system, the new Showermate offers the ultimate solution to poor performance. The new Pumps:

- Are fully automatic.
- Are supplied complete with 15 mm flexible hoses.
- Offer more power and efficiency than ever before.
- Supplied pre-wired with 1.5 metre cable and anti-vibration feet.
- Reassurance of up to a 2-year guarantee (subject to conditions)

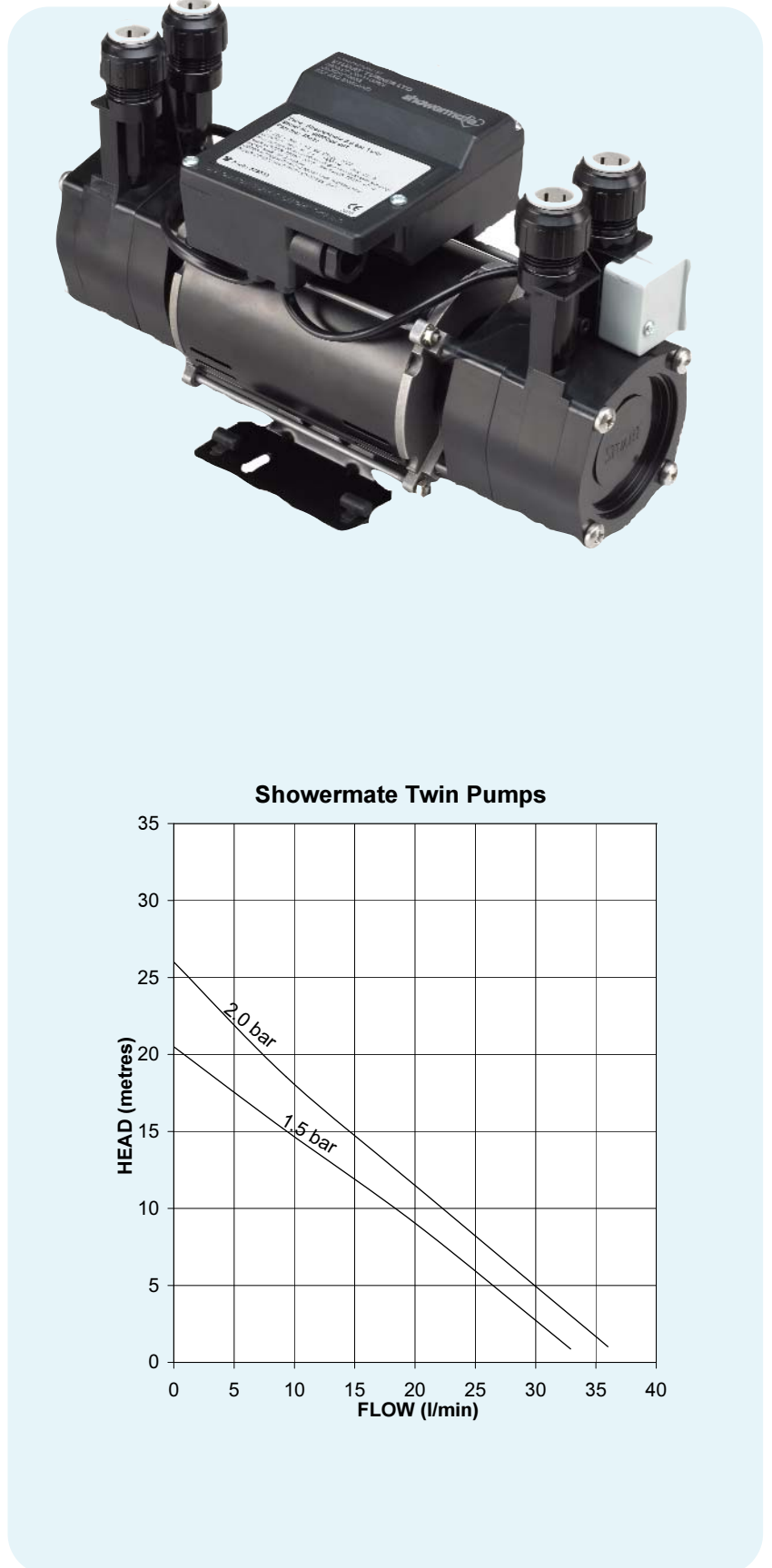

Showermate Twin Pumps

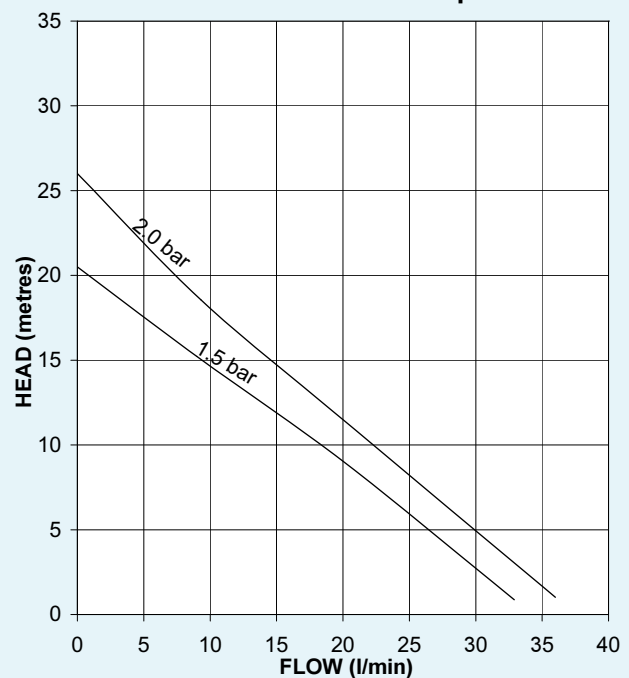

2

year guarantee!

subject to
conditions



Showermate Standard Twin Pumps

System Booster Pumps	1.5-1.8 bar max Twin 46407	2.0-2.6 bar max Twin 46431
Performance (bar) @ 9 l/min	1.5	1.9
Maximum Flow Litres Per Minute	33	36
Maximum Head Valve Closed (bar)	1.8	2.6
Maximum Inlet Static Head (Metres)	13	13
Hoses Flexible 15 mm Push-In	✓	✓
Pump Connection 15 mm Push-In	✓	✓
Carbon Ceramic Mechanical Seal	✓	✓
Flow Switch Sensitivity approx. 0.8 l/min	✓	✓
Negative Airswitch Option Available	✓	✓
WRAS Approved 65°C max	✓	✓
Power Supply 230/1/50	✓	✓
Enclosure Rating BS EN 60529	IP22	IP22
Motor Type, Induction, Permanent Capacitor, Auto Resetting Protective Thermotrip	✓	✓
Nominal Power Consumption (Watts) @ 9 l/min	355	420
Full Load Amps	1.9	2.4
Fuse Rating Amps	5	5
Pre-Wired	✓	✓
Duty Rating Intermittent (S3) 30 mins on/ 30 mins off @ 9 l/min	✓	✓
Length mm	306	323
Width mm	130	130
Height mm without flexibles	185	185
Gross Weight Packed (kg)	5.6	6.3

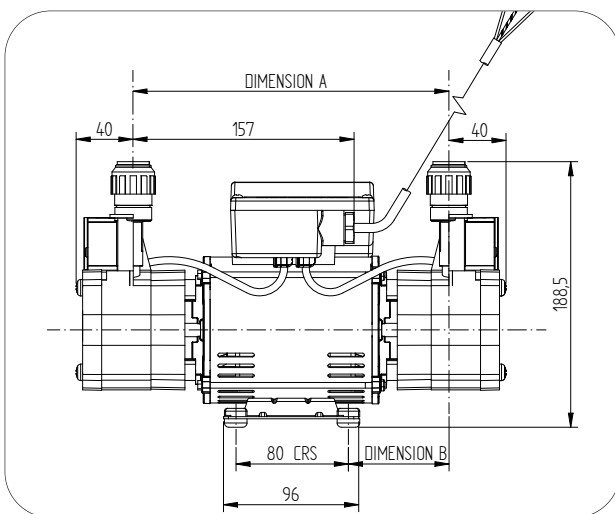

Pump description	Dim. 'A'	Dim. 'B'
1.5-1.8 bar Twin	224 mm	71.4 mm
2.0-2.6 bar Twin	239 mm	78.8 mm



Stuart Turner Ltd
Henley-on-Thames
Oxfordshire RG9 2AD
England
Telephone: +44 (0)1491 572655
Fax: +44 (0)1491 573704

Email:
pumps@stuart-turner.co.uk
Web:
www.stuart-turner.co.uk

V.A.T. REG. No. 199 0987 92.
Registered in England No. 88368.
Registered Office:
Market Place, Henley-on-Thames