

Monsoon Standard Single Pumps

Where an open vented positive head system exists with a minimum gravity flow of 0.6 l/min, then the Monsoon Standard is the perfect solution.

Standard single pumps are ideal for boosting water pressure and flow.

They can be used to:

- Boost the water pressure in either the hot or cold water supply.
- Boost the blended water outlet between the shower valve and the shower rose.

Not suitable for pumping water supplies to common mixers.

- All pumps supplied with 22 mm push-in x 300 mm anti-vibration flexible hoses.
- All flexible hoses feature integral isolating valves.
- All pumps supplied pre-wired with 1.5 metre cable, anti-vibration feet.
- All pumps have G $\frac{3}{4}$ threaded connections.
- Reassurance of up to a 5-year guarantee (subject to conditions)



Monsoon Standard Single Pumps

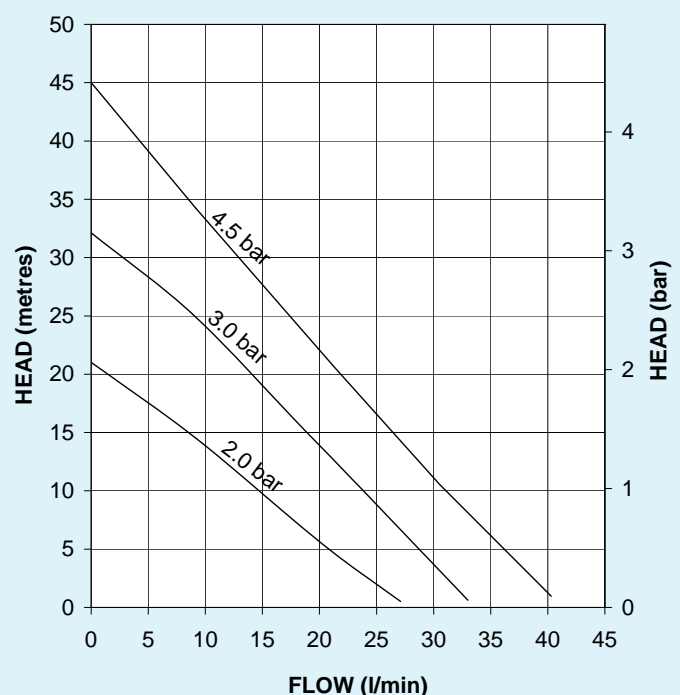

Monsoon Standard Single Pumps

| System Booster Pumps | | 2.0 bar Single 46497 | 3.0 bar Single 46419 | 4.5 bar Single 46420 |
|--|--|----------------------------|----------------------------|----------------------------|
| Performance (bar) @ 9 l/min (one shower) | | 1.5 | 2.5 | 3.5 |
| Performance (bar) @ 18 l/min (two showers) | | 0.7 | 1.6 | 2.4 |
| Maximum Flow Litres Per Minute | | 27 | 33 | 40 |
| Maximum Head Valve Closed (bar) | | 2.0 | 3.0 | 4.5 |
| Maximum Inlet Static Head (Metres) | | 8 | 14 | 14 |
| Hoses | G ¾" Female x 22 mm Push-in c/w isolating valves x 305 mm long | ✓ | ✓ | ✓ |
| G ¾" Male Pump Connections | | ✓ | ✓ | ✓ |
| Inlet Strainer | | ✓ | ✓ | ✓ |
| Stuart Hard Faced Mechanical Seal | | ✓ | ✓ | ✓ |
| WRAS Approved 65°C max | | ✓ | ✓ | ✓ |
| Flow Switch Sensitivity approx. 0.6 l/min | | ✓ | ✓ | ✓ |
| Pressure Switch | | | | |
| PCB | Run On Timer 3 Sec | | | |
| | Dry Run Protection | ✓ | ✓ | ✓ |
| Power Supply 230/1/50 | | ✓ | ✓ | ✓ |
| Enclosure Rating BS EN 60529 | | IPX4 | IPX4 | IPX4 |
| Motor Type, Induction, Permanent Capacitor, Auto Resetting Protective Thermotrip | | ✓ | ✓ | ✓ |
| Power Consumption (Watts) | | 245 | 385 | 555 |
| Full Load Amps | | 1.1 | 1.7 | 2.4 |
| Fuse Rating Amps | | 5 | 5 | 5 |
| Pre-Wired | | ✓ | ✓ | ✓ |
| Duty Rating Continuous (S1) @ 9 l/min and above | | ✓ | ✓ | ✓ |
| Length mm | | 200 | 200 | 200 |
| Width mm | | 126 | 126 | 126 |
| Height mm without flexibles | | 202 | 202 | 202 |
| Gross Weight Packed (kg) | | 6.5 | 6.5 | 7.1 |

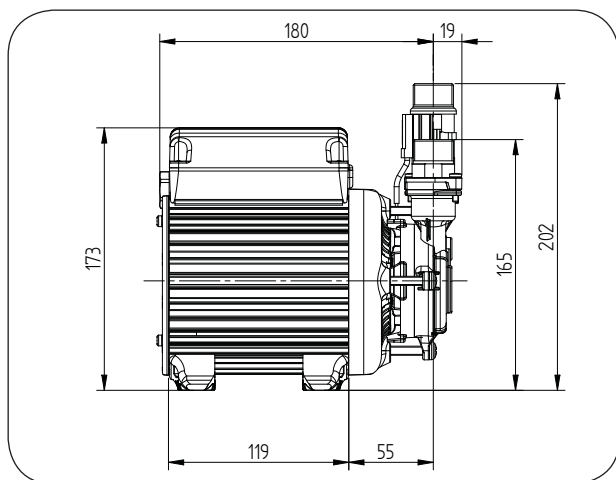

Stuart Turner Ltd
Henley-on-Thames
Oxfordshire RG9 2AD
England
Telephone: +44 (0)1491 572655
Fax: +44 (0)1491 573704

Email:
pumps@stuart-turner.co.uk
Web:
www.stuart-turner.co.uk

V.A.T. REG. No. 199 0987 92.
Registered in England No. 88368.
Registered Office:
Market Place, Henley-on-Thames