

Monsoon Standard Single Pumps

Where an open vented positive head system exists with a minimum gravity flow of 0.6 l/min, then the Monsoon Standard is the perfect solution.

Standard single pumps are ideal for boosting water pressure and flow.

They can be used to:

- Boost the water pressure in either the hot or cold water supply.
- Boost the blended water outlet between the shower valve and the shower rose.

Not suitable for pumping water supplies to common mixers.

- All pumps supplied with 22 mm push-in x 300 mm anti-vibration flexible hoses.
- All flexible hoses feature integral isolating valves.
- All pumps supplied pre-wired with 1.5 metre cable, anti-vibration feet.
- All pumps have G $\frac{3}{4}$ threaded connections.
- Reassurance of up to a 3-year guarantee (subject to conditions)



Monsoon Standard Single Pumps

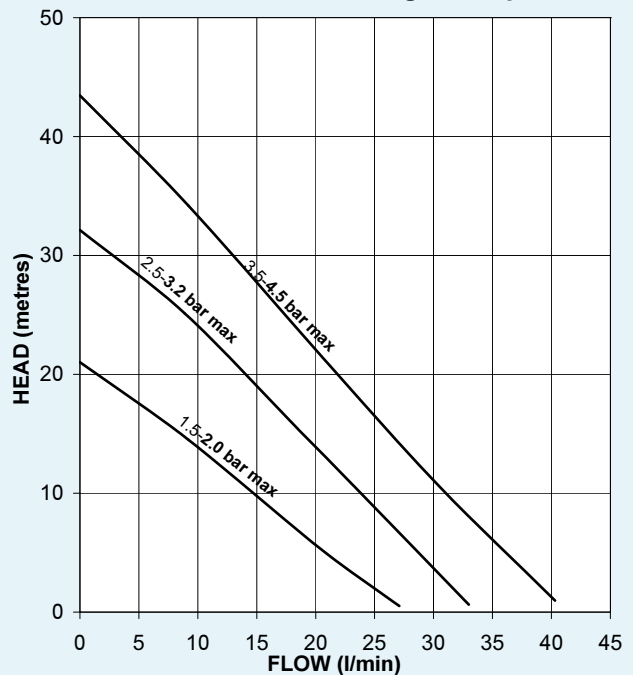

3

year guarantee!

subject to conditions

Monsoon Standard Single Pumps

System Booster Pumps		1.5-2.0 bar max Single 46497	2.5-3.2 bar max Single 46419	3.5-4.5 bar max Single 46420
Performance (bar) @ 9 l/min (one shower)		1.5	2.5	3.5
Performance (bar) @ 18 l/min (two showers)		0.7	1.6	2.4
Maximum Flow Litres Per Minute		27	33	40
Maximum Head Valve Closed (bar)		2.0	3.2	4.5
Maximum Inlet Static Head (Metres)		14	14	14
Hoses	G $\frac{3}{4}$ " Female x 22 mm Push-in c/w isolating valves x 305 mm long	✓	✓	✓
G $\frac{3}{4}$ " Male Pump Connections		✓	✓	✓
Inlet Strainer		✓	✓	✓
Stuart Hard Faced Mechanical Seal		✓	✓	✓
WRAS Approved 65°C max		✓	✓	✓
Flow Switch Sensitivity approx. 0.6 l/min		✓	✓	✓
Pressure Switch				
PCB	Run On Timer 3 Sec			
	Dry Run Protection	✓	✓	✓
Power Supply 230/1/50		✓	✓	✓
Enclosure Rating BS EN 60529		IPX4	IPX4	IPX4
Motor Type, Induction, Permanent Capacitor, Auto Resetting Protective Thermotrip		✓	✓	✓
Nominal Power Consumption (Watts) @ 9 l/min		192	285	435
Full Load Amps		1.1	1.7	2.4
Fuse Rating Amps		5	5	5
Pre-Wired		✓	✓	✓
Duty Rating Continuous (S1) @ 9 l/min and above		✓	✓	✓
Length mm		200	200	200
Width mm		126	126	126
Height mm without flexibles		202	202	202
Gross Weight Packed (kg)		6.5	6.5	7.1

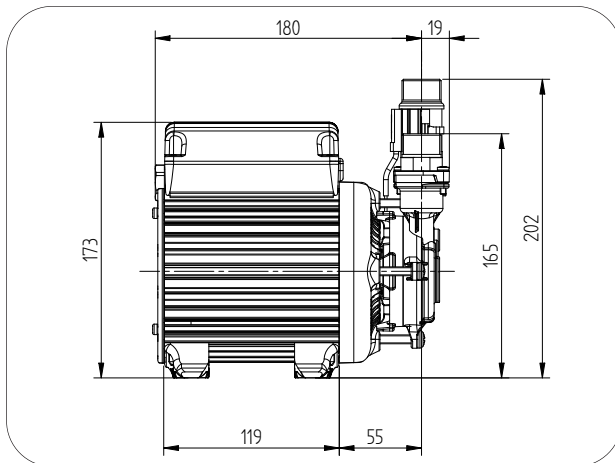

Stuart Turner Ltd
Henley-on-Thames
Oxfordshire RG9 2AD
England
Telephone: +44 (0)1491 572655
Fax: +44 (0)1491 573704

Email: pumps@stuart-turner.co.uk
Web: www.stuart-turner.co.uk

V.A.T. REG. No. 199 0987 92.
Registered in England No. 88368.
Registered Office:
Market Place, Henley-on-Thames