

Submersible Pumps

With integral automatic float switch

The Supersub VA300 and VA600 Submersible pumps offer a compact design ideal for general purpose applications where space is at a premium. A simple lever allows quick selection of manual or automatic mode of operation. Both models are supplied complete with non-return valve and stepped hose union.

Application

The Supersub VA300 and VA600 are both ideal for transfer of rain, dirty or waste water, where automatic control is required in a confined space, cellar drainage is a popular application.

Features

- Automatic-vertical float switch.
- Switch for automatic/manual mode.
- Suction to a remaining depth of 3-6 mm (manual mode).
- Suction to a remaining depth of 35 mm (auto mode).
- Passes suspended solids up to 5 mm diameter.
- Motor can be partially submerged for short term operation.
- Top vertical outlet connection.
- VA600 is available as an option with a 110V, 50 Hz motor.

Materials

Body	Polypropylene
Impeller	Noryl
Motor casing	304 Stainless steel
Pump shaft	304 Stainless/ceramic
Seal	Three separate lip seals

Operating Conditions

Max. water temp.	35°C
Min. water temp.	4°C
Max. immersion depth	7 m

Cable

H05RN-F3	10 m
----------	------

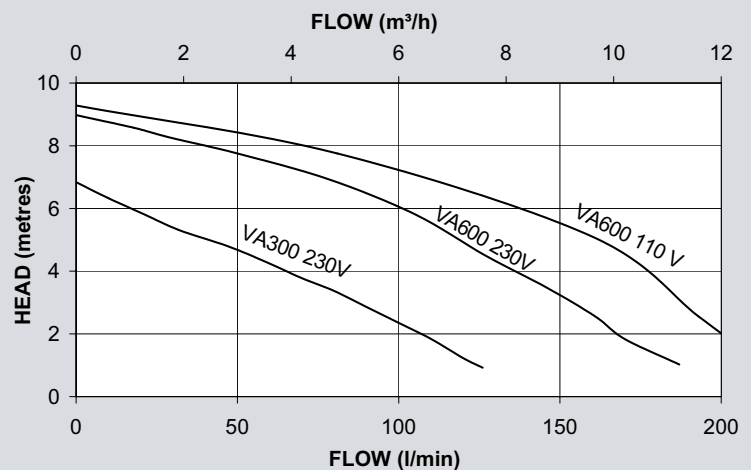

Submersible Pumps

With integral automatic float switch

Model	Motor*	Nominal watts	Watts full flow	Amps full load	Impeller	Seal	Carton dims. mm			Gross weight Kg	Part no.
							L	x W	x H		
VA300	230/1/50	180	275	1.2	Noryl	Triple Lip	430	x 240	x 210	5.0	46357
VA600	230/1/50	350	508	2.2	Noryl	Triple Lip	430	x 240	x 210	5.7	46358
VA600	110/1/50	450	635	6.3	Noryl	Triple Lip	430	x 240	x 210	5.7	46365

*Built to IP68, all motors are designed for continuous running and feature thermal overload protection. A residual current device having a rated current not exceeding 30 mA must be installed in the supply circuit.

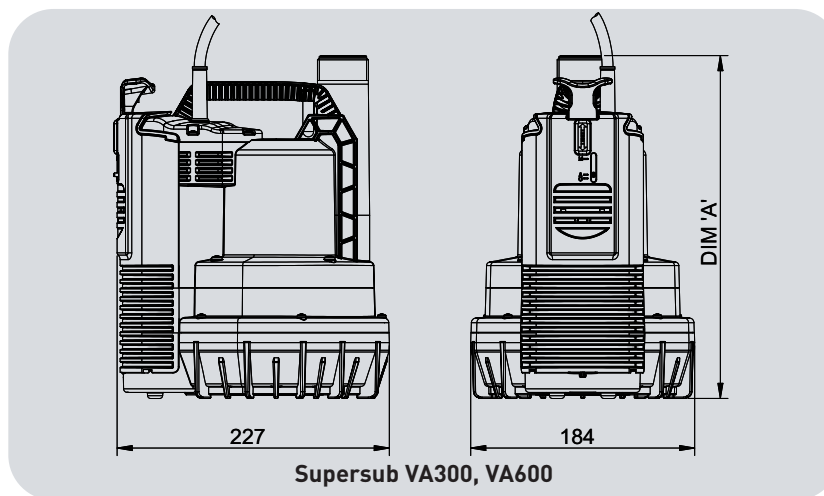
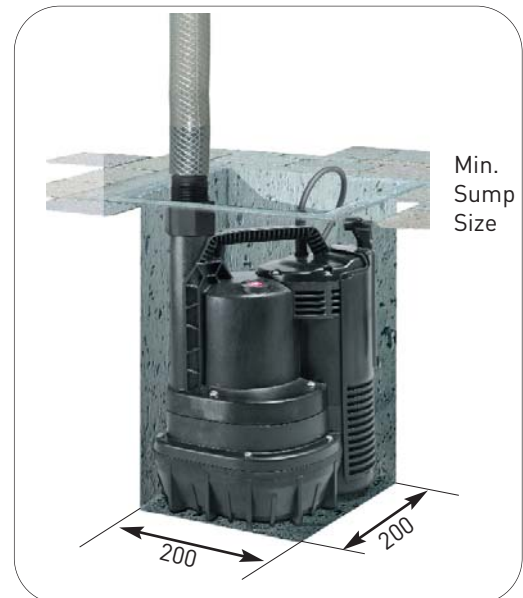
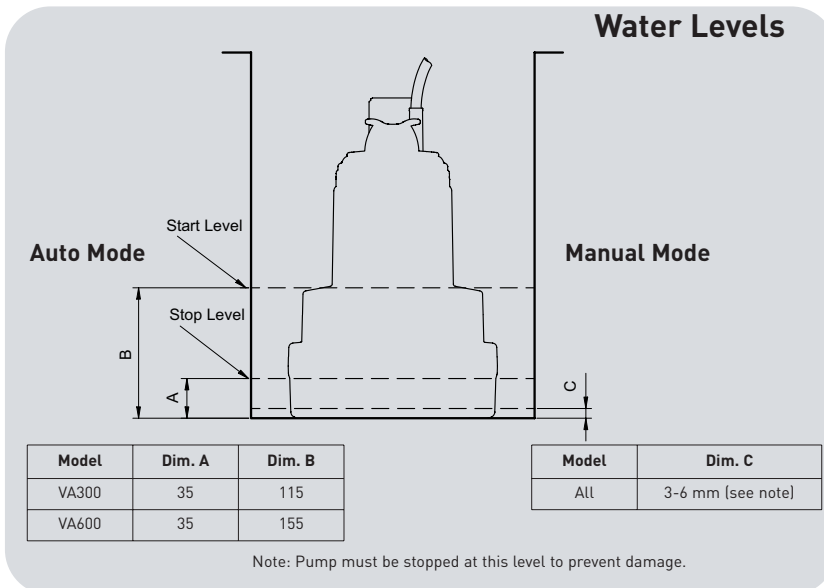

Pump description	Dim. 'A'
Supersub VA300	282
Supersub VA600	318

All dimensions shown are in mm.

Stuart Turner Ltd
Henley-on-Thames
Oxfordshire RG9 2AD
England

Telephone:
+44 (0)1491 572655
Fax:
+44 (0)1491 573704

Email:
pumps@stuart-turner.co.uk
Web:
www.stuart-turner.co.uk

**STUART
TURNER LTD**