

# Monsoon Standard Twin Pumps

Where an open vented positive head system exists with a minimum gravity flow of 0.6 l/min, then the Monsoon Standard is the perfect solution.

Standard twin pumps are designed for installation into both the hot and cold water supply- boosting both equally.

They can be used to:

- Boost hot and cold water services to the complete home, bathroom, kitchen or cloakroom.
- Boost hot and cold water supplies to a high performance shower system.
- All pumps supplied with 22 mm push-in x 300 mm anti-vibration flexible hoses.
- All flexible hoses feature integral isolating valves.
- All pumps supplied pre-wired with 1.5 metre cable, anti-vibration feet.
- All pumps have G $\frac{3}{4}$  threaded connections.
- Reassurance of up to a 3-year guarantee (subject to conditions)



**Monsoon Standard Twin Pumps**

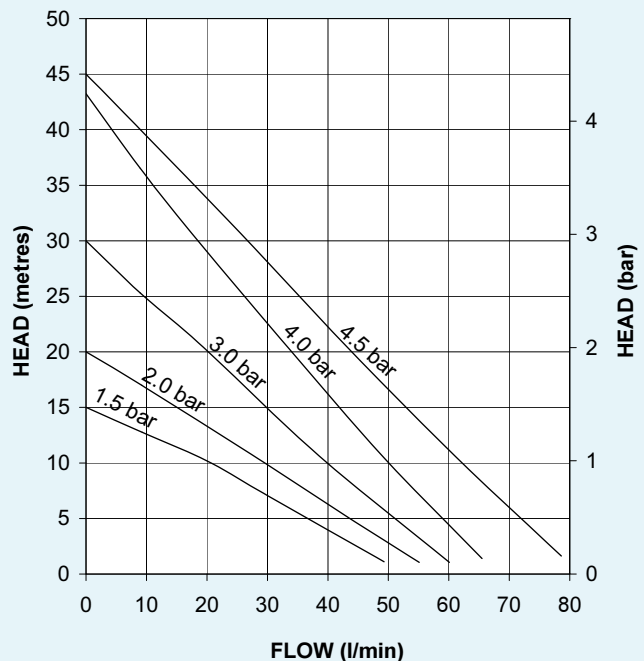

**3**  
year guarantee!  
subject to conditions



# Monsoon Standard Twin Pumps

System Booster Pumps	1.5 bar Twin 46506	2.0 bar Twin 46415	3.0 bar Twin 46416	4.0 bar Twin 46417	4.5 bar Twin 46418
Performance (bar) @ 9 l/min (one shower)	1.2	1.5	2.5	3.5	3.9
Performance (bar) @ 18 l/min (two showers)	1.1	1.3	2.1	3.0	3.4
Maximum Flow Litres Per Minute	49	55	60	65	78
Maximum Head Valve Closed (bar)	1.5	2.0	3.0	4.2	4.5
Maximum Inlet Static Head (Metres)	14	14	14	14	14
Hoses	G <sup>3</sup> / <sub>4</sub> " Female x 22 mm Push-in c/w isolating valves x 305 mm long				
G <sup>3</sup> / <sub>4</sub> " Male Pump Connections	✓	✓	✓	✓	✓
Inlet Strainer	✓	✓	✓	✓	✓
Stuart Hard Faced Mechanical Seal	✓	✓	✓	✓	✓
WRAS Approved 65°C max	✓	✓	✓	✓	✓
Flow Switch Sensitivity approx. 0.6 l/min	✓	✓	✓	✓	✓
Pressure Switch					
PCB	Run On Timer 3 Sec				
	Dry Run Protection				
Power Supply 230/1/50	✓	✓	✓	✓	✓
Enclosure Rating BS EN 60529	IPX4	IPX4	IPX4	IPX4	IPX4
Motor Type, Induction, Permanent Capacitor, Auto Resetting Protective Thermotrip	✓	✓	✓	✓	✓
Power Consumption (Watts)	345	425	640	980	1090
Full Load Amps	1.5	1.9	2.8	4.0	4.9
Fuse Rating Amps	5	5	5	13	13
Pre-Wired	✓	✓	✓	✓	✓
Duty Rating Continuous (S1) @ 9 l/min and above	✓	✓	✓	✓	✓
Length mm	265	265	265	300	310
Width mm	126	126	126	126	126
Height mm without flexibles	202	202	202	202	202
Gross Weight Packed (kg)	8.4	8.4	8.7	10.7	11.4

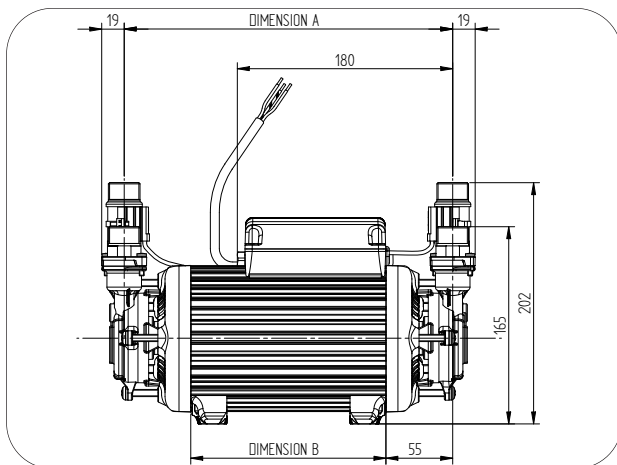

Pump description	Dim. 'A'	Dim. 'B'
1.5 bar Twin	227 mm	119 mm
2.0 bar Twin	227 mm	119 mm
3.0 bar Twin	262 mm	154 mm
4.0 bar Twin	272 mm	164 mm
4.5 bar Twin	272 mm	164 mm



Stuart Turner Ltd  
Henley-on-Thames  
Oxfordshire RG9 2AD  
England  
Telephone: +44 (0)1491 572655  
Fax: +44 (0)1491 573704

Email: pumps@stuart-turner.co.uk  
Web: www.stuart-turner.co.uk

V.A.T. REG. No. 199 0987 92.  
Registered in England No. 88368.  
Registered Office:  
Market Place, Henley-on-Thames