

Installation Instructions For Monsoon Extra Pressure Sets: 3.2 bar PS 4.7 bar PS



INDEX.....	Page No
Application	1
Storage	1
Typical Installation	2
Pre-Installation Check	2
Pump Location	2
Sequence of Operation	4
Pipework Connections	4
Pump Connections	5

INDEX.....	Page No
Electrical Installation	8
Commissioning	12
Maintenance	13
Trouble Shooting Guide	15
Technical Specification	17
Noise	17
Environment Protection	17

PRODUCT DESCRIPTION

Electric motor driven centrifugal pump, complete with pressure vessel and automatic control system, consisting of flow and pressure switches and electronic controls.

APPLICATION

The Monsoon Extra pressure set range is designed for cold water pressure boosting applications to hot or cold clean water systems. Inlet pressures to the pump and ambient temperatures must not exceed the values given in the technical specifications.



- **This pump set must not be used for any other application without the written consent of Stuart Turner Limited and in particular, must not be connected directly to the mains water supply.**
- **This appliance is not intended for use by persons (including children) with reduced physical, sensory or mental capabilities, or lack of experience and knowledge, unless they have been given supervision or instruction concerning use of the appliance by a person responsible for their safety.**
Children should be supervised to ensure that they do not play with the appliance.

STORAGE

If this product is not to be installed immediately on receipt, ensure that it is stored in a dry, frost and vibration free location in its original packaging.

**Please leave this instruction booklet with the pump as it
contains maintenance and safety information
(Original Instructions)**

TYPICAL INSTALLATION



The plumbing installation must comply with the following:

The Water Supply (Water Fittings) Regulations 1999.

BS6700 and building regulations.

Be installed by a competent person.

- If in doubt contact **Stuart Turner Ltd**

This diagram should be used for schematic reference only

- 1: Isolating valve
- 2: Inlet strainer
- 3: Flexible hose

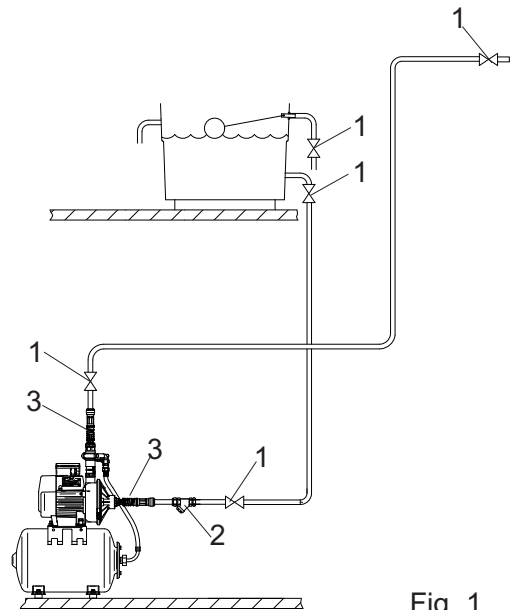

Fig. 1

STEP 1 PRE-INSTALLATION CHECK

Your pump set comprises of two major parts, the main pump and pressure vessel. The pressure vessel is pre-charged with air at the factory to 140 kPa (1.4 bar or 20.3 psi). This pressure should be checked at the Schrader valve using a tyre pressure gauge and adjusted if necessary using a car or bicycle pump prior to installation.

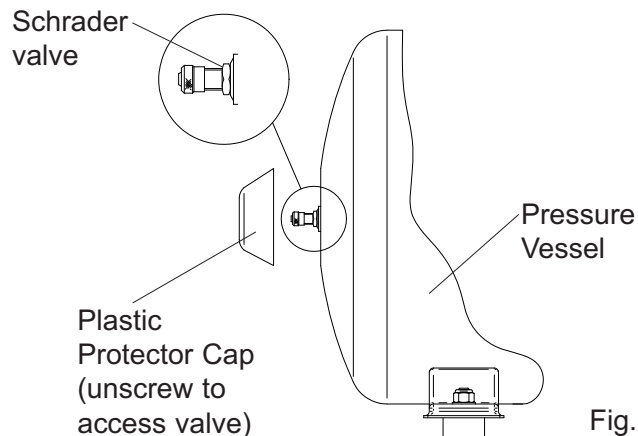

Fig. 2

STEP 2 PUMP LOCATION (General)

WARNINGS:



- The pump must not be located where the inlet pressure to the pump is greater than permitted.
- Care should be taken to protect pump from frost and freezing, particularly when located in a loft installation.
- **Pump Location**
If possible site the pump in a location where in the unlikely event of a water leak, any spillage is contained or routed to avoid electrics or areas sensitive to water damage.
- The motor casing can become very hot under normal operating conditions, care should be taken to ensure it cannot be touched during operation.
- Ensure all components in the down-stream system to be pressurised are suitably rated to accommodate the final system working pressure.

The pump must be installed so that the following conditions are met:

Locate the pump in a frost free horizontal position where it cannot be sprayed with water and as close to the water source as possible, having a minimum flooded suction head of 1 metre at all times. Ensure the water flow is in the direction of the arrow that is marked on the flow switch reed clamp (vertically upwards).

The pump is started by a pressure switch and stopped by a flow switch, enabling the unit to function in both positive or negative head installations.

Before deciding where to position the unit, check to ensure the static inlet head of water above the pump does not exceed 10 metres (Fig. 3). The static outlet head of water above the pump must not exceed 13 metres (Fig. 3).

The pump must be installed on its anti-vibration mounting feet and must not be screwed down.

Typical pump locations are in an airing cupboard, or inside a purpose built dry and ventilated enclosure. The enclosure should have a minimum clearance of 80 mm (3 ") between the pump and housing on all sides. The enclosure should be secure and access should only be available by the use of tools.

Typical Installation

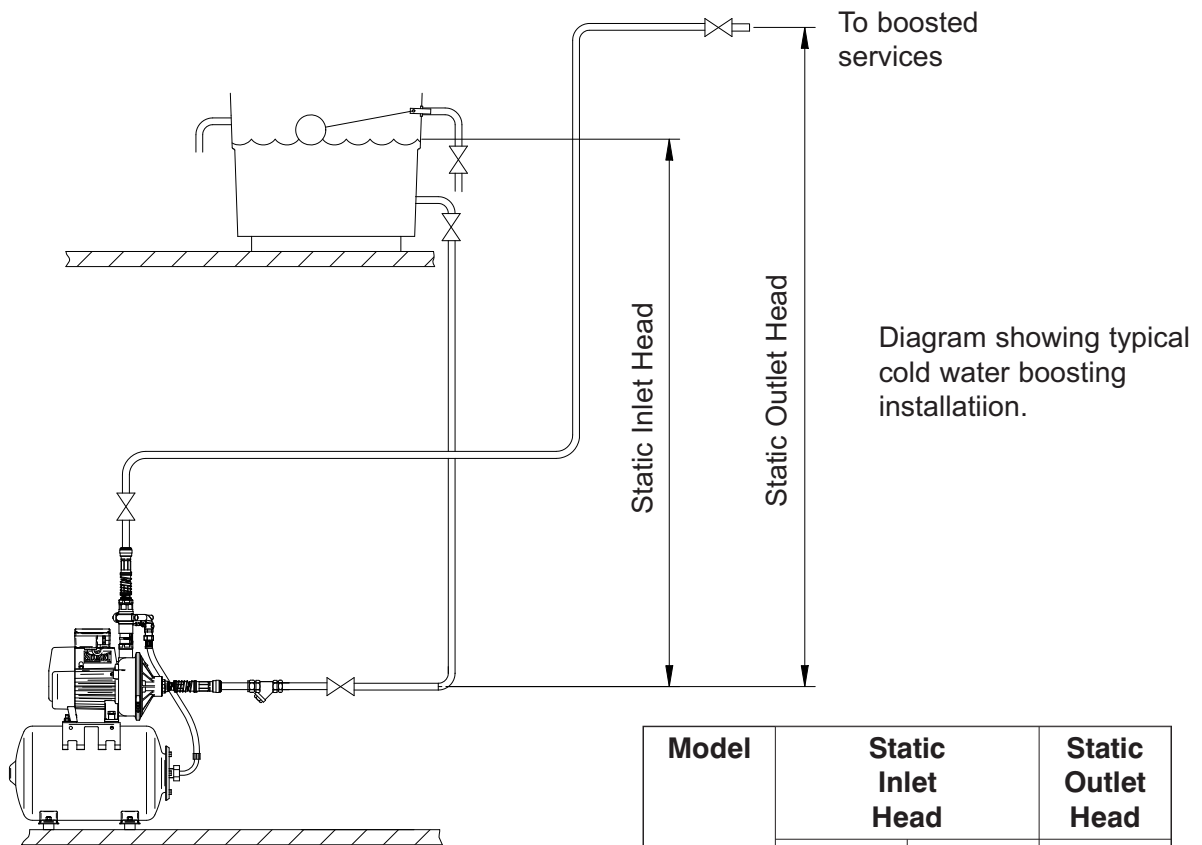

Fig. 3

Model	Static Inlet Head		Static Outlet Head
	Min. metres	Max. metres	Max. metres
3.2	1	10	13
4.7			

STEP 3 SEQUENCE OF OPERATION

The pressure vessel is able to provide for small demands of water, limiting pump starts to the larger demand requirements. The sequence of operation for the pump set is as follows:-

1. A terminal fitting in down-stream boosted system is opened, causing water to flow from fitting.
2. Pressure vessel satisfies initial demand by exhausting it's pre-charged stored water capacity.
3. As vessel is exhausted, system pressure falls to pressure switch cut in level.
4. Pump starts and takes over water flow requirements from pressure vessel.
5. Terminal fitting in down-stream boosted system is closed causing flow to stop.
6. Flow switch sensor detects loss of flow activity as flow falls to 1 l/min or less.
7. Pump will stop after the pressure vessel stored water charge is replenished.
8. Pump set is now ready for next demand requirement.

STEP 4 PIPEWORK CONNECTIONS (General)

WARNINGS:



- **Ensure pipework to and from pump is independently supported to prevent forces being transferred to inlet and outlet branches of pump.**
- **Do not introduce solder flux to pumps or pump parts manufactured from plastic. All solder joints should be completed and flux residues removed prior to pump connection.**
- **Do not allow contact with oil or cellulose based paints, paint thinners or strippers, acid based descalents or aggressive cleaning agents.**
- **Always install isolating valves to both suction and delivery pipework.**
- **Do not install a non-return valve, or devices which contain non-return valves, in the suction (inlet) pipework to the pump. The pump must be free to vent to the supply tank at all times.**

It must be ensured that the water storage capacity is sufficient to meet the flow rates required by the pump and any other water using fittings and appliances, which may be operated simultaneously.

The pipework feeds to the storage tank should be of adequate size to ensure replenishment rate of tank is sufficient to meet needs of pump.

The pump must be supplied with a dedicated feed direct from the water storage tank.

To prevent loss of water pressure through pipework use 28 mm suction pipework to the pump minimising 90° bends.

Isolating valves (not supplied) should be fitted on the suction and delivery pipework to enable easy isolation and access to the pump.

The 1" inline strainer as supplied should be fitted in the suction line to the pump between the isolating valve and the pump. This will eliminate the risk of debris or scale entering the pump.

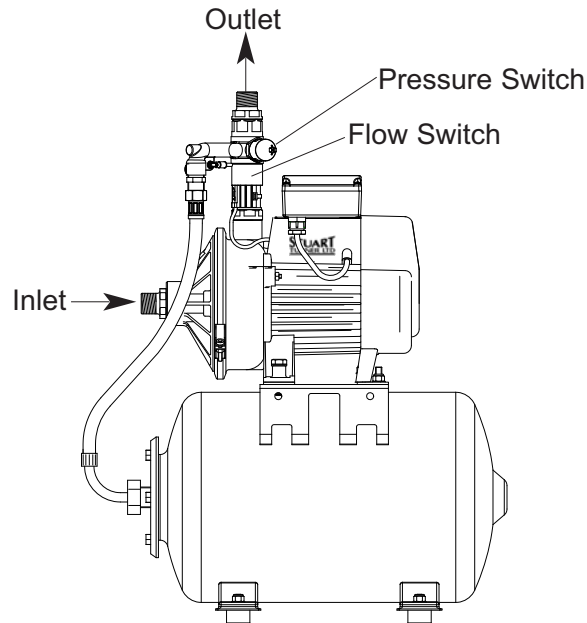

Fig. 4

Pipework Connections (Connection between pump and down-stream services to be boosted)

This should run as far as possible in 22 mm copper tube. Any bend requirements should be achieved by hand drawing the tube or by use of the appropriate bend fittings. Pipework should only be reduced to 15 mm copper if necessary when entering any terminal fittings of this size. By this method the maximum performance of the pump will be maintained. All pipework should be securely clipped.

STEP 5 PUMP CONNECTIONS (Release And Connection Of Push-in Connectors)

WARNINGS: (Push-in Connectors)



- **Do not use stainless steel, chrome or nickel plated pipe with Stuart Turner push-in plumbing connections.**
- **Do not introduce solder flux into the joint or surrounding area as connectors will be attacked and may fail. All solder joints should be completed and flux residues removed before final connection to push-in connections, either on flexible hose or pump head.**
- **Do not allow contact with oil or cellulose based paints, paint thinners or strippers, acid based descalents or aggressive cleaning agents.**

Hose to Pump

The pump inlet and outlet ports have factory assembled fittings which are specifically designed for connection to the G³/₄ female running nuts on the flexible hoses. The hose end is fitted with a rubber sealing washer which is held captive within the nut assembly. Locate the hose into position and screw the nut fully onto the fitting by hand. finally nip tight with a spanner (4/5 Nm) for a water tight seal (**do not overtighten**).

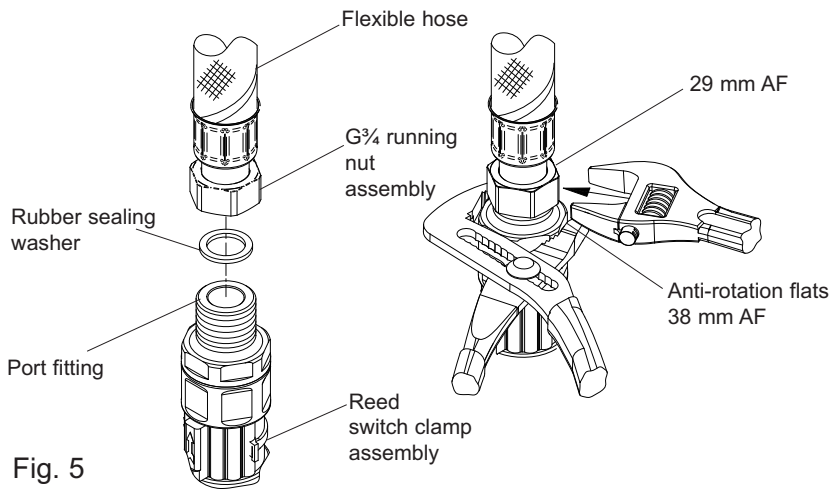

Note: When tightening or loosening the hose nut assembly, the anti-rotation flats provided on the inlet and outlet fittings should be used for placement of a second spanner as shown. This is to prevent complete assembly rotation. It may be necessary to partially rotate the reed switch clamp assembly on the outlet fitting to avoid damage during placement of the second spanner.

Fig. 5

Hose to Pipework

1. Stuart Turner recommend only the use of their 22 mm flexible hoses. The hoses are fitted with plastic push-in connectors, which must only be connected with the following:
 - a) 22 mm diameter copper pipe to BS EN 1057 - R250 (half hard) - Table 3.
 - b) 22 mm plastic pipe to BS 7291 part 1 and part 2 (Table 1), or part 3 (Table 1) plus internal support sleeve*.
 - * The internal bore of the plastic pipe must be supported against collapse with the pipe manufacturers' recommended support sleeve (pipe insert).
 - c) Appropriate plumbing fittings from the John Guest 'speedfit' push-in plumbing fitting range.

Other manufacturers' fittings are not necessarily compatible and may not provide a water tight connection.

Ensure the pipe is free from all score marks and deformities in the area of the insertion depth (Fig. 6) and cut the pipe square removing all burrs and sharp edges to prevent damage to the sealing 'O'-ring.

2. Prior to inserting pipe into fitting mark the insertion depth on the wall of the pipe with a soft pencil at a distance of 35 mm from the end to be inserted (Fig. 6).

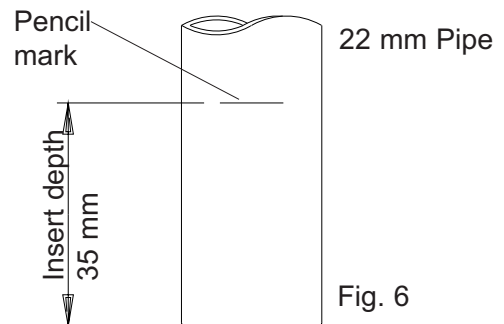

Fig. 6

3. Check in the mouth of the fitting that 'O'-ring, nylon washer and collet are in position.

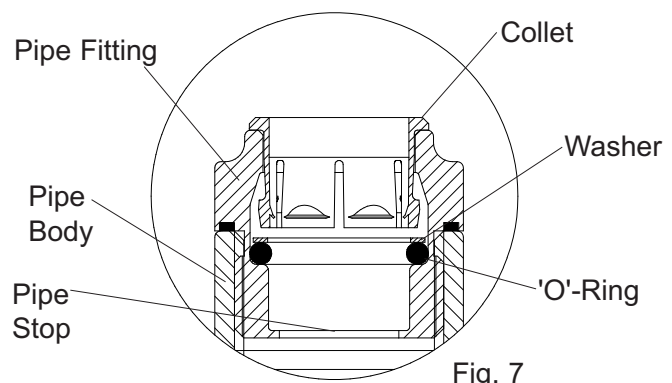

Fig. 7

4. Push pipe firmly into fitting, until pencil mark is level with the top of the collet and the pipe stop resistance is felt. Pull on pipe to check it is secure and correctly fitted.
5. To release the joint, push pipe firmly into fitting, hold the collet down and gently remove pipe. If the system has been filled with water care should be taken to isolate pump and towels used to absorb spilled water.

If you have any concern either about using push-in fittings or should the joint leak on final test, isolate the water supplies and contact Pump Assist on 0844 98 000 97.

Pump Connections (General)



22 mm flexible pipes with push-in connections. Ensure that connections are fully pushed home into mating connector and that hoses are kept as straight as possible. In the case of horizontal feeds use a 22 mm John Guest stem elbow (not supplied). Do not bend the hose more than 30° as they may become damaged, transmit noise or leak.

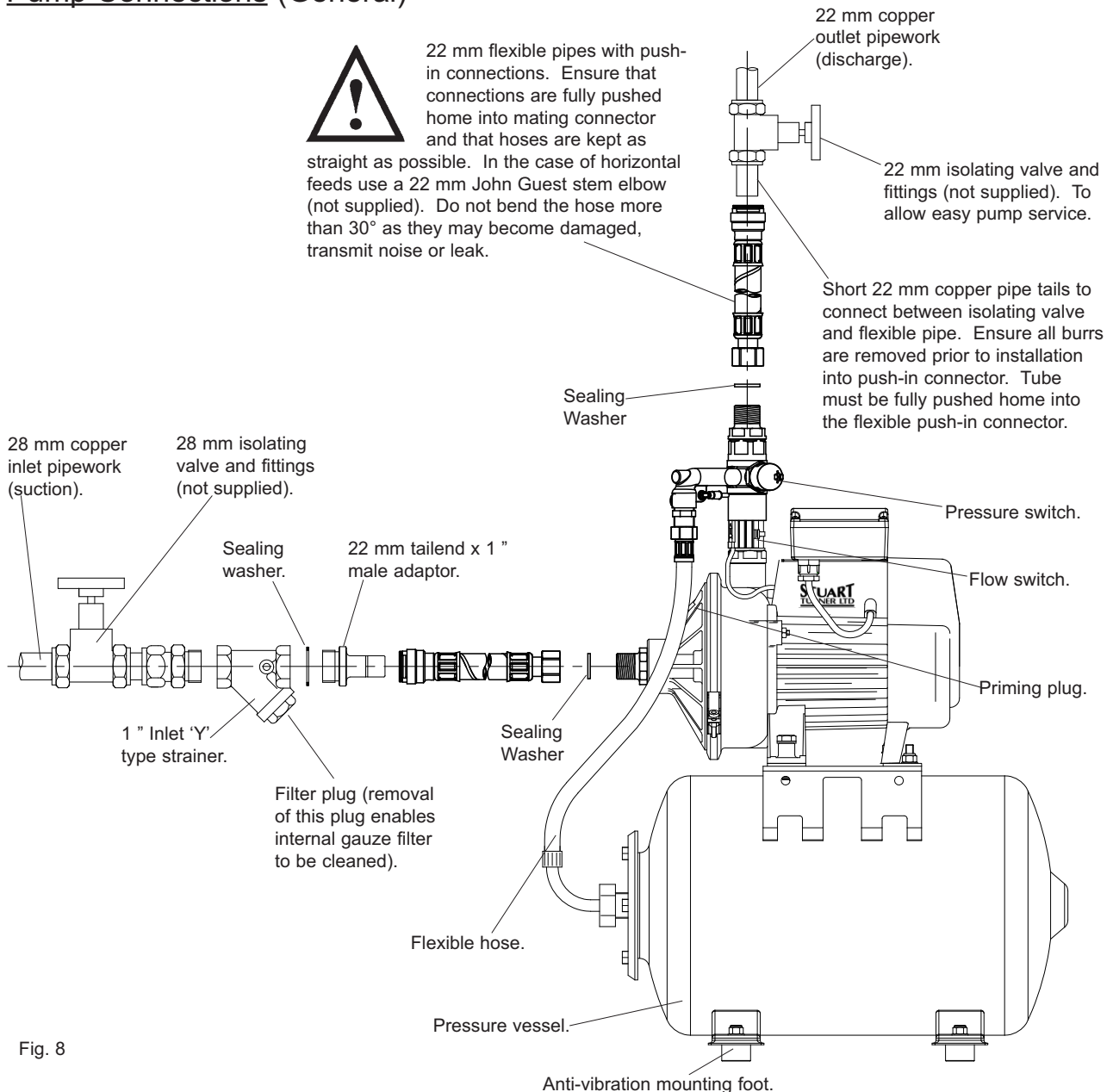

Fig. 8

The pump set should not be screwed down, ensure anti-vibration feet and flexible hoses are used.

STEP 6 ELECTRICAL INSTALLATION

WARNINGS:



- The electrical installation must be carried out in accordance with the current national electrical regulations and installed by a competent person.
- In the interests of electrical safety a 30mA residual current device (R.C.D.) should be installed in the supply circuit. This may be part of a consumer unit or a separate unit.
- The motor and wiring must not be exposed to water.
- Before starting work on the electrical supply ensure power supply is isolated.

The motor fitted to this pump is suitable for a 230/1/50Hz supply. It is thermally protected by an integral auto resetting thermotrip for your safety and rated for the duty listed in the technical specification section.

Electrical Connection

The motor is provided with a factory fitted supply cord. This must be permanently connected to the fixed wiring of the mains supply. Means for disconnection must be incorporated in the fixed wiring in accordance with the wiring rules.

A suitable method of connection would be via a double pole switched, fused connection unit complying with BS 1363-4, protected with a fuse (see fuse section).

The connection unit should be mounted in an easily accessible position and should be labelled if confusion is possible, to allow easy identification of the pump isolating switch.

Cont....

Earthing

This appliance must be earthed via the supply cord, which must be correctly connected to the earth point located in the terminal box.

Copper or metallic pipework must have supplementary earth bonding where the continuity has been broken by flexible hoses or plastic components. Adjacent suction and delivery pipes should be fitted with earthing clamps to BS 951 and connected with earthing wire size 4 mm² (Fig. 9). A standard kit is available from Stuart Turner (Part No. 17044).

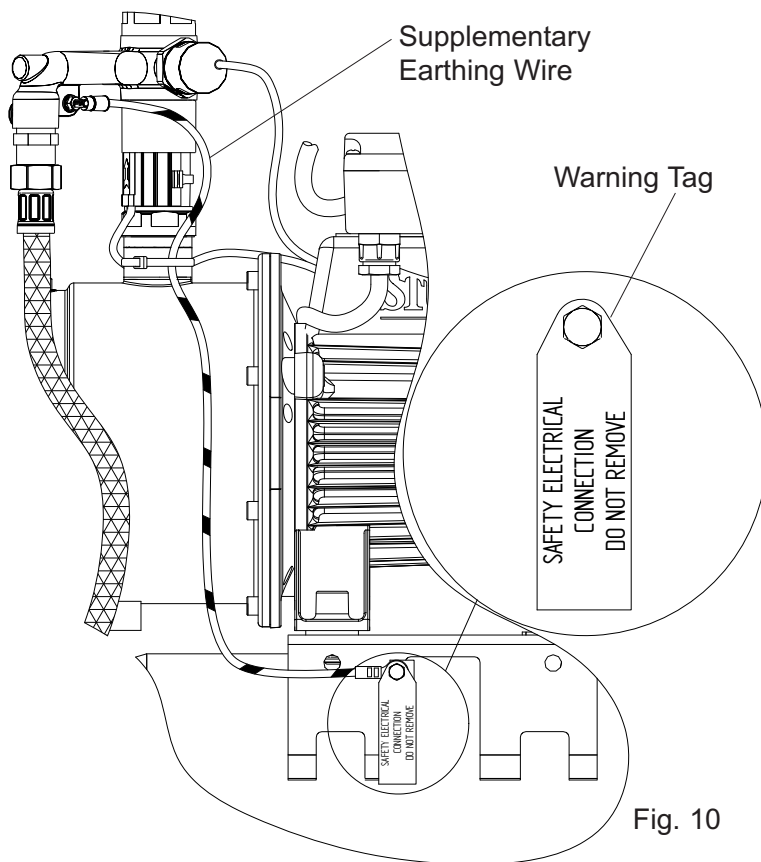
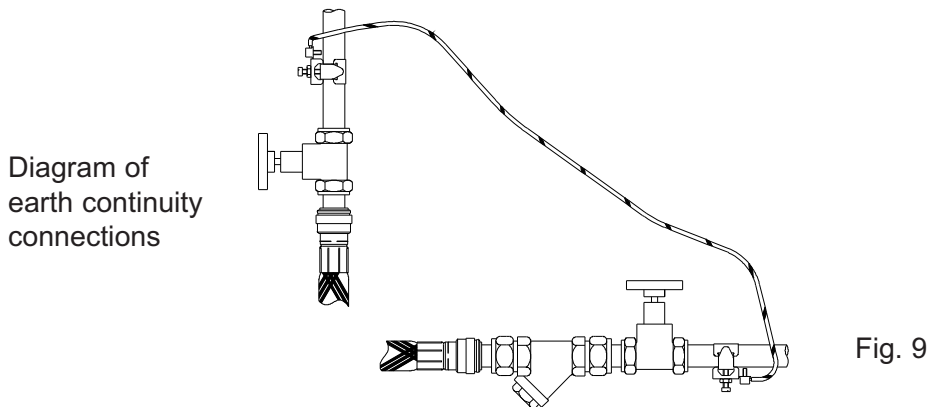

The pressure set is factory fitted with a supplementary earthing wire to ensure continuity throughout the assembly (Fig. 10). It must be ensured throughout the product life that this electrical connection remains in place.

A warning tag with the words to this effect is attached to the electrical connection.



Factory fitted supplementary earth bond. Do not remove or disturb.

Certain installations may require additional earthing arrangements such as equipotential bonding. Reference should be made to the relevant regulations concerning this subject to ensure compliance.

Wiring Of Connection Unit



WARNING: This appliance must be earthed.

The wires in the mains lead are coloured in accordance with the following code:

Green and Yellow: Earth Blue: Neutral Brown: Live

As the colours of the wires in the mains lead of this appliance may not correspond with the coloured markings identifying the terminals in your connection unit proceed as follows:

The wire which is coloured green and yellow must be connected to the terminal in the connection unit which is marked with the letter E or by the earth symbol:  or coloured green or green and yellow.

The wire which is coloured blue must be connected to the terminal which is marked with the letter N or coloured black.

The wire which is coloured brown must be connected to the terminal which is marked with the letter L or coloured red.

Wiring Diagram



The supply cord and internal wiring within the terminal box are routed and secured to ensure compliance with the electrical standard EN 60335-1. It is essential that any disturbance of this internal wiring is avoided and the factory routing and securing of all internal wiring is always maintained.

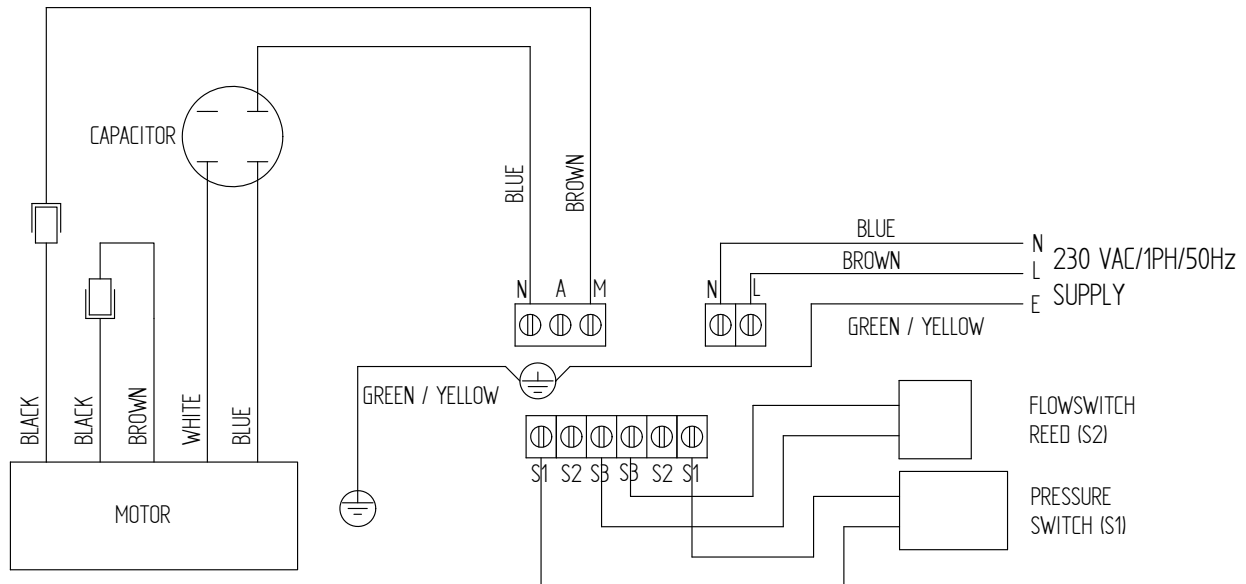

Fig. 11

Fuses

The following fuse size should be used with the appropriate pump:

Model	Fuse Size (Amps)
All models	13

Supply Cord Replacement

If the supply cord is to be changed or is damaged, it must be replaced with a special cord assembly available from Stuart Turner or one of their approved repairers.

On disassembly note the cord retention and routing system. Reassemble to the same pattern.

For information on cable connection consult the wiring diagram and cable gland fitting instructions.

Intermediate Connecting Cord Replacement

These pumps incorporate an additional cord which connects the main terminal box to the motor terminal box. If this cord is damaged, it must be replaced with a special cord assembly available from Stuart Turner or one of their approved repairers.

On disassembly note the cord retention and routing system. Re-assemble to the same pattern.

For information on cable connection consult the wiring diagram.

Supply Cord Extension

The pumps are fitted with a supply cord to the following specification:-

HO7RN-F3 G 1.0 mm² - 10 Amp rated cable.

If the supply cord is to be extended, a cord of the same specification should be used. Any connections or junction boxes used should be specifically suited for the application and installed in accordance with the manufacturers' instructions.

Cable Gland Fitting Instructions

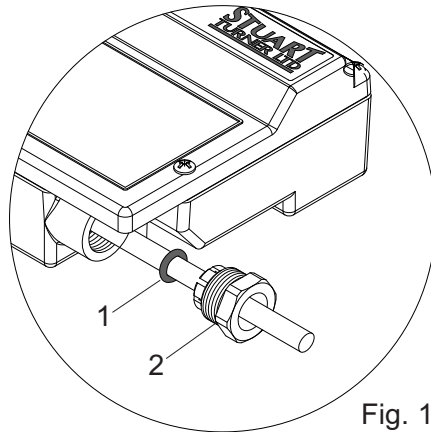

Fig. 12

To enable correct assembly of the cable gland the 'O'-ring (1) must be placed over the cable before the clamping insert (2) can be tightened.

Note: Cable diameter range:- 6.5 mm to 9.5 mm.

STEP 7 COMMISSIONING

WARNINGS:



- The motor casing can become very hot under normal operating conditions, care should be taken to ensure it cannot be touched during operation.
- Do not run pump without guards and terminal box lid correctly fitted.
- The pump chamber must be full of water at all times. Seal damage will result if the pump runs dry.



1. System Flushing

This pump incorporates push-in connectors and plastic components that must not come into contact with solder flux, acid-based descalents or aggressive cleaning agents. The pipework system should be flushed out prior to the pump being connected to ensure any contaminants/chemical residues and foreign bodies are removed from elsewhere in the system.



2. Water Supply

Always ensure that water storage capacity is adequate to meet the demand. Ensure the pump chamber is full of water before starting the pump. Failure to do this could result in seal damage. To ensure dry running does not occur the pump must be primed as described in the priming section. **Do not run pump dry.**

3. Priming

The pump must be primed (filled with water) before starting. Turn on water supply, prime and vent the pump by unscrewing the priming plug (Figs. 13 & 14) slowly until all air escapes and water emerges. Re-tighten the plug.

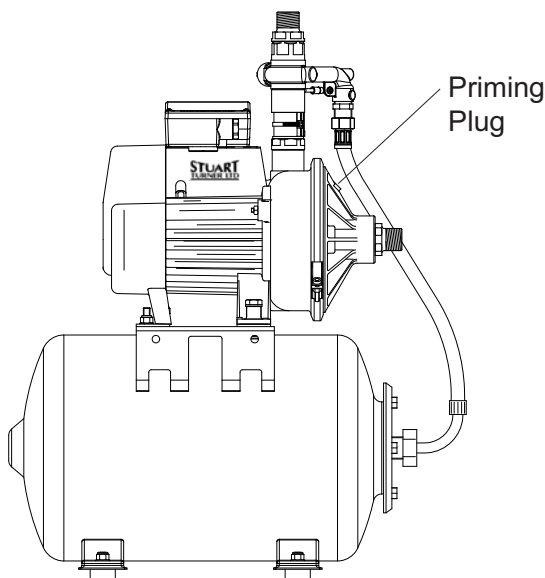

Monsoon Extra 3.2 PS
Fig. 13

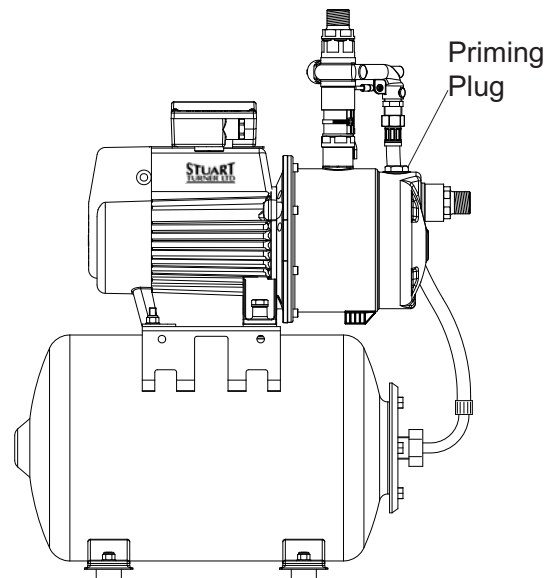

Monsoon Extra 4.7 PS
Fig. 14

4. Pre-Start Check

Always ensure the static inlet and outlet heads above the pump do not exceed the permitted maximum (see pump location section).

5. Starting The Pump

- a) Ensure all outlets are closed, turn power supply 'on' - pump will start, pressurise the system then stop.
- b) Open and close all outlets in turn associated with the pump, (including w/c systems) allowing water to flow from each outlet until all air is purged. As each outlet is opened the vessel will discharge its stored water until pressure falls when pump will start and satisfy demand.
After closing the outlet there will be a delay before the pump stops, which is normal.
Any tap or control valve within the system when opened and closed will now initiate this sequence of events. Providing this is the case the system is now operating correctly.
- c) Carefully check pump and pipework for leaks whilst pump running and stationary before leaving the installation unattended.

For Further Technical Support

Phone the Stuart Turner Pump Assist team on 0844 98 000 97. Our staff are trained to help and advise you over the phone or arrange for a service engineer to call.

MAINTENANCE

WARNINGS:



- **Care should be taken to protect pump from frost and freezing, particularly when located in a loft installation.**
- **Pump Location**

If possible site the pump in a location where in the unlikely event of a water leak, any spillage is contained or routed to avoid electrics or areas sensitive to water damage.



1. No routine maintenance is required but provision should be made for easy access to the pump to allow for repairs due to normal wear and tear.
2. Disconnect electrical supply before working on pump.
3. Turn off water supplies to the pump and release pressure by opening water outlets before attempting maintenance.
4. The inlet strainer incorporates a removable gauze filter which may require periodical cleaning. The frequency of this operation is dependent upon installation conditions. The strainer is located in the inlet pipework to the pump (see page 7). The gauze filter is removed as follows:-
 - a) Isolate pump electrically.
 - b) Release all system pressure.
 - c) Isolate water supply.
 - d) Remove screwed hexagonal plug from strainer body (see page 7).
 - e) Remove and clean stainless steel gauze filter.
 - f) Reassemble gauze and secure plug tightly.
 - g) See commissioning section for instructions on re-starting pump.

5. The pressure vessel air pre-charge does not require routine maintenance. Should ever the need arise for the vessel to have its air pre-charge checked or replenished, it should be carried out as follows: -
- a) Isolate pump electrically.
 - b) Isolate cold inlet water supply by closing the appropriate valve.
 - c) Release system water pressure by opening a system outlet (tap).
 - d) Check air pre-charge at Schrader valve (Fig. 2) using a tyre pressure gauge. Pressure should be 140 kPa (1.4 bar or 20.3 psi).
 - e) Replenish air charge if required by injecting air into the vessel via the Schrader valve using a car or bicycle pump, ensuring a system outlet valve (tap) remains open during this procedure to allow the vessel to exhaust any excess water.
 - f) Close all system taps, open cold inlet isolating valve, turn on electrical power.
 - g) After maintenance is completed refer to commissioning section for instructions on re-starting pump.

Cleaners, Disinfectants and Descalents



On installations where chemical disinfectants or descalents are periodically used, the compatibility of the chemical solution regarding the pump must be considered.

Acid based descalents and aggressive cleaning agents must not come into contact with the pump. The pump must be removed from the system prior to the use of these products. The system should be flushed to remove all chemicals before the pump is re-connected.

If in any doubt as to the suitability of the chemical solutions, please contact our Pump Assist helpline.

Cont...

TROUBLE SHOOTING GUIDE

Symptoms	Probable Cause	Recommended Action
Pump will not start.	<p>Water supply.</p> <p>Filter blocked.</p> <p>Electrical supply.</p> <p>Incorrect installation.</p> <p>Integral auto resetting motor thermotrip activated.</p>	<p>Check water level in the supply tank and all stopcocks are open.</p> <p>Remove and clean system filters.</p> <p>Check wiring connections. Check all switches are 'on'. Check correct fuse fitted. Check circuit breaker is set.</p> <p>Check inlet and outlet static heads are within permitted limits (see pump location section).</p> <p>Allow to cool and investigate cause of problem before restarting.</p>
No water.	<p>Water feed.</p> <p>Boiler is switched off.</p> <p>Faulty thermostatic mixer valve.</p>	<p>Check water level in cold water tank and that all stopcocks are open.</p> <p>Check boiler is switched 'on'. Check cylinder thermostat. Check immersion heater. Check cylinder contains hot water.</p> <p>Consult makers instructions.</p>
Pump starts when outlets are off.	<p>Leak in system.</p>	<p>Check tap washers, ball valve washers, pipe joints.</p>
Pump runs on when all terminal outlets are closed.	<p>Leak in system.</p> <p>Reed clamp out of position.</p> <p>Faulty reed switch/PCB.</p> <p>Jammed flow switch.</p> <p>Faulty reed switch or P.C.B.</p>	<p>Check tap washers, w/c valve washers, pipe joints.</p> <p>Ensure reed clamp is fitted correctly in location groove (Fig. 14).</p> <p>Refer to circuit test as detailed in Fig. 14.</p> <p>Remove flow switch reed clamp whilst pump is running, if pump stops proceed to isolate the pump electrically and hydraulically and remove brass housing that contains float. Check for free movement.</p> <p>Remove flow switch reed clamp whilst pump is running. If pump continues to run, this indicates a closed circuit in either the flow switch reed or P.C.B. in the terminal box, these should be checked electrically.</p>
Reduced flow/performance.	<p>Blocked inlet strainer.</p>	<p>Clean inlet strainer (see maintenance section).</p>

Flow Switch Circuit Test

1. First confirm visually that the flow switch reed clamp has not been dislodged during handling or installation. The clamp must be fully located within the flow switch body groove as shown.
2. To carry out the following test you will need to obtain a magnet, a typical fridge magnet is suitable.
3. Ensure the power supply is switched on.
4. Position the magnet directly in front of the reed clamp as shown. If pump does not start, then slowly move the magnet up and down to a position that exceeds the extent of the reed clamp. The pump should instantaneously start at some point during this extent of movement. If this does not happen, this indicates a possible fault with the reed switch or the P.C.B which is located within the terminal box. These should be checked electrically. Consult Stuart Turner for further instructions.

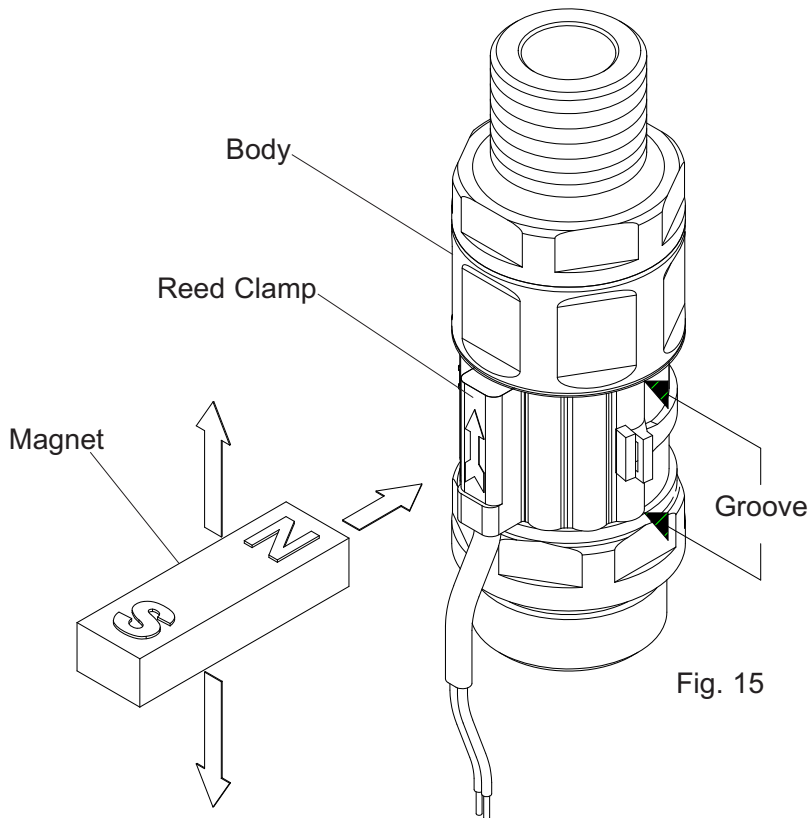

TECHNICAL SPECIFICATION

Model		3.2 bar	4.7 bar
Electrical	Power supply Volts/phase frequency	230/1/50	230/1/50
	Motor enclosure	IPX4	IPX4
	Type of motor	Induction	Induction
	Power consumption	880 Watts	1060 Watts
	Full load current	3.9 Amps	4.9 Amps
	Rating	Continuous (S1)	Continuous (S1)
	Max. No Starts per hour	60	60
Mechanical	Max inlet pressure	10 metres	10 metres
	Max head (Closed Valve)	30.5 metres	47 metres
	Max working pressure*	400 kPa (4.0 bar)	600 kPa (6.0 bar)
	Max ambient air temperature	40°C	40°C
	Max water temperature	35°C	35°C
	Min water temperature	4°C	4°C
Dimensions	Length (excluding flexible hoses)	541 mm	530 mm
	Width	275 mm	275 mm
	Height (excluding flexible hoses)	665 mm	668 mm
	Gross weight (packed) (including accessories)	16 Kg	18 Kg

Stuart Turner reserve the right to amend the specification in line with it's policy of continuous development of its products.

*Note: Max working pressure is the maximum pressure that can be applied to the pump internal casing under any installation conditions.

Note: For information on other voltages/frequencies which are not shown, consult any supplementary instruction sheet supplied, or the rating label attached to the pump.

NOISE

The equivalent continuous A-weighted sound pressure level at a distance of 1 metre from the pump does not exceed 70 dB(A).

ENVIRONMENT PROTECTION

Your appliance contains valuable materials which can be recovered or recycled.

At the end of the products' useful life, please leave it at an appropriate local civic waste collection point.

GOOD PRACTICE

Always flush system prior to starting a new or serviced pump.

Always ensure the pump is primed (filled with water) before starting. **DO NOT RUN PUMP DRY.**

Always ensure the pump has a minimum flooded suction head of 1 metre at all times.

Always ensure anti-vibration feet are used.

Ensure pump is sited in dry ventilated position.

Do not allow pressure set to freeze.

Abide by the Water Supply (Water Fittings) Regulations 1999.

Always install isolating valves to both suction and delivery pipework.

Ensure earth continuity between suction and delivery pipes.

Always ensure pump wiring conforms with the current national electrical regulations and installed by a competent person.

Do not install a non-return valve, or devices which contain non-return valves, in the suction (inlet) pipework to the pump. The pump must be free to vent to the supply tanks at all times.

Disconnect electrical supply before working on pump or motor.

Carefully check pump and pipework for leaks before leaving the installation unattended.

YOUR 2 YEAR GUARANTEE

Stuart Pumps are guaranteed by Stuart Turner Limited to be free from defects in materials or workmanship for the applicable guarantee period from the date of purchase. The applicable guarantee period is stated in the installation booklet supplied with the pump. Within the guarantee period we will repair, free of charge, any defects in the pump resulting from faults in material or workmanship, repairing, exchanging parts or exchanging the whole unit as we may reasonably decide.

Not covered by this guarantee: Damage arising from incorrect installation, improper use, unauthorised repair, normal wear and tear and defects which have a negligible effect on the value or operation of the pump.

Reasonable evidence must be supplied that the pump has been purchased within the applicable guarantee period prior to the date of claim (such as proof of purchase or the pump serial number).

This guarantee is in addition to your statutory rights as a consumer. If you are in any doubt as to these rights, please contact your local Trading Standards Department or Citizen's Advice Bureau.

In the event of a claim please telephone Stuart Turner Limited on 0844 980 0097 or return your pump and flexible hoses with accessories removed, plugs, pipes etc. If you have any doubt about removing a pump, please consult a professional.

Proof of purchase should accompany the returned pump to avoid delay in investigation and dealing with your claim.

Please record here for your records.

TYPE NO.	SERIAL NO.	DATE PURCHASED



DECLARATION OF CONFORMITY

2006/42/EC

BS EN ISO 12100-1, BS EN ISO 12100-2, BS EN 809

2006/95/EC

BS EN 60335-1, BS EN 60335-2-41, EN 50366

2004/108/EC

BS EN 55014-1, BS EN 55014-2, BS EN 55022, BS EN 61000-3-2, BS EN 61000-3-3,
BS EN 61000-4-2, BS EN 61000-4-3, BS EN 61000-4-4, BS EN 61000-4-5, BS EN 61000-4-6,
BS EN 61000-4-11

IT IS HEREBY CERTIFIED THAT THE STUART ELECTRIC MOTOR DRIVEN PUMP AS
SERIAL NUMBER BELOW, COMPLIES WITH THE ESSENTIAL REQUIREMENTS OF THE
ABOVE E.E.C. DIRECTIVES.



RESPONSIBLE PERSON
AND MANUFACTURER

STUART TURNER LIMITED
HENLEY-ON-THAMES, OXFORDSHIRE
RG9 2AD ENGLAND.

Signed

Customer Relationship Manager

Stuart Turner are an approved company to BS EN ISO 9001:2000

STUART TURNER

Stuart Turner Ltd, Henley-on-Thames, Oxfordshire RG9 2AD ENGLAND

Tel: +44 (0) 1491 572655, Fax: +44 (0) 1491 573704

email: pumps@stuart-turner.co.uk web: www.stuart-turner.co.uk

V.A.T. REG. No. 199 0987 92. Registered in England No. 88368. Registered Office: Market Place, Henley-on-Thames