

STUART TURNER LTD HENLEY-ON-THAMES.

THIRD ANGLE PROJECTION

DIMENSIONS IN MILLIMETRES

NOTE:
THE PRESSURE VESSEL CAN BE RE-POSITIONED IF REQUIRED TO SUIT SPECIFIC INSTALLATIONS, HOWEVER, CARE MUST BE TAKEN WHEN RE-POSITIONING TO ENSURE NO STRAIN IS PLACED UPON THE PRESSURE SWITCH OR FLOW SWITCH CABLES.

MODEL	DIMENSION				
	A	B	C	D	E
MONSOON EXTRA U4.5 bar SINGLE	447.5	101.5	131.5	161	299

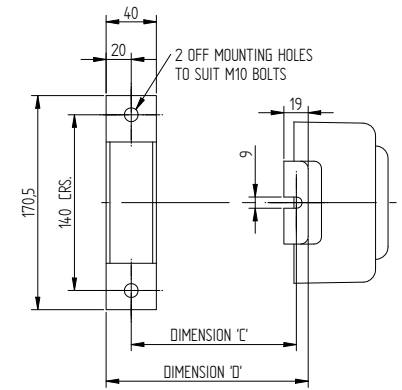
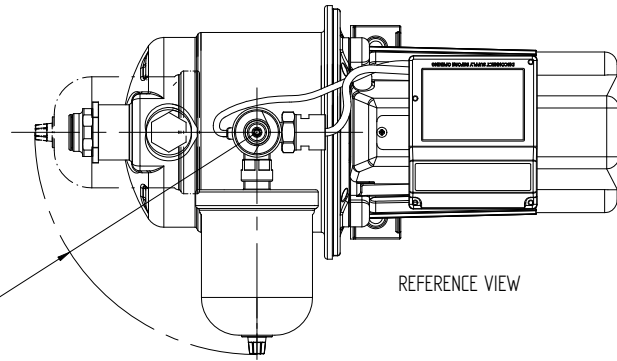

VIEW ON ARROW X
MOUNTING FOOT DETAIL
SCALE 12

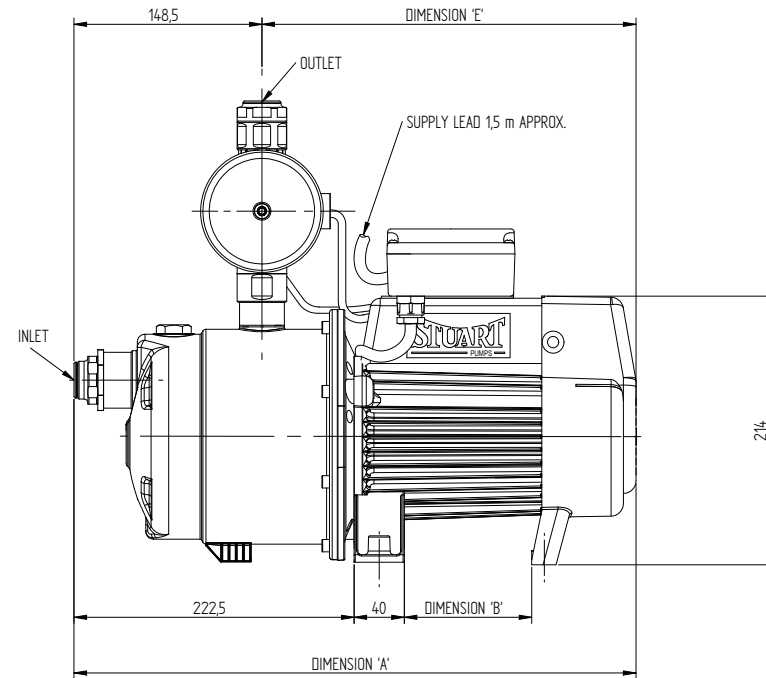
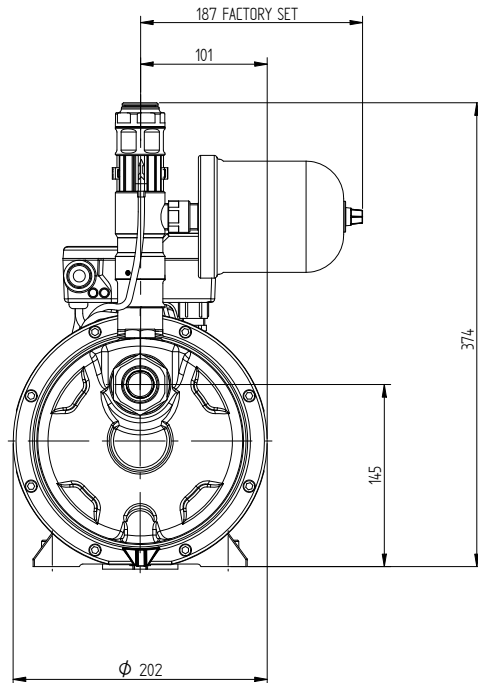

NOTE:-
INLET AND OUTLET = 22 mm PUSH FIT

If drawing is to be used for constructional purposes please contact Stuart Turner Ltd and request a certified document.

Stuart Turner Ltd reserves the right to amend specifications without notice.

Stuart Turner Ltd own the copyright within this document. The document may be printed for personal use only. The document must not be altered, reproduced or utilized in any way without written permission from Stuart Turner Ltd, Henley-on-Thames, Oxon, UK.

GENERAL ARRANGEMENT OF A MONSOON EXTRA U4.5 bar SINGLE

W41343

DATE: 02/03/2010