

# STUART TURNER LTD HENLEY-ON-THAMES.

If drawing is to be used for constructional purposes please contact Stuart Turner Ltd and request a certified document.

THIRD ANGLE PROJECTION

DIMENSIONS IN MILLIMETRES

MODEL	DIMENSION			
	A	B	C	D
MONSOON EXTRA 4.5 bar	443	1015	1315	161

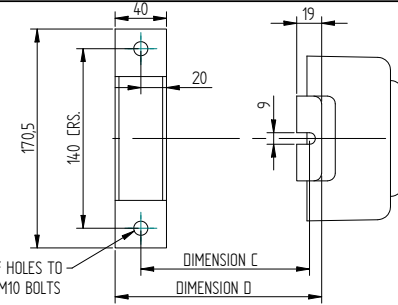

SUPPLY LEAD  
1.5 m APPROX.

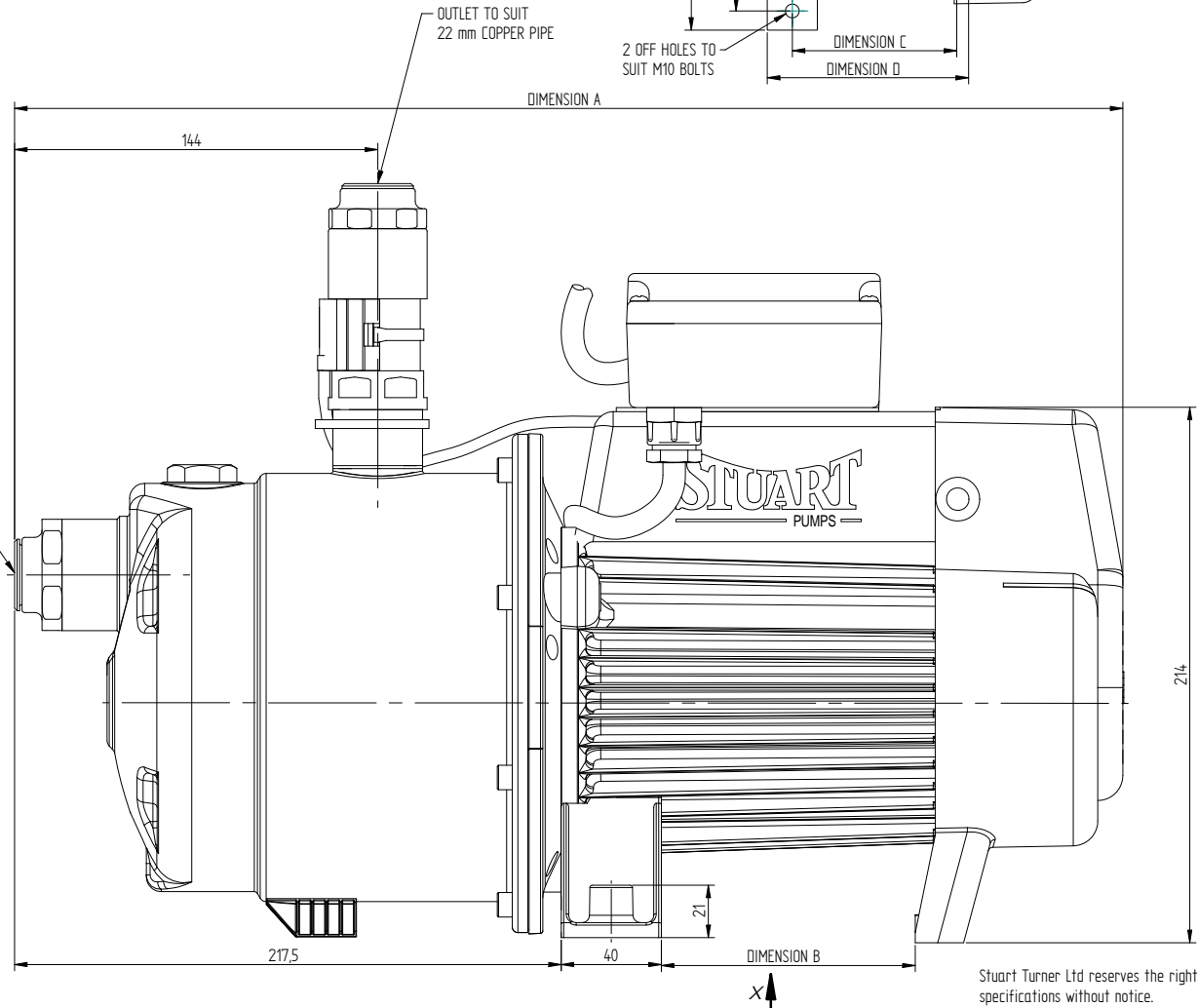
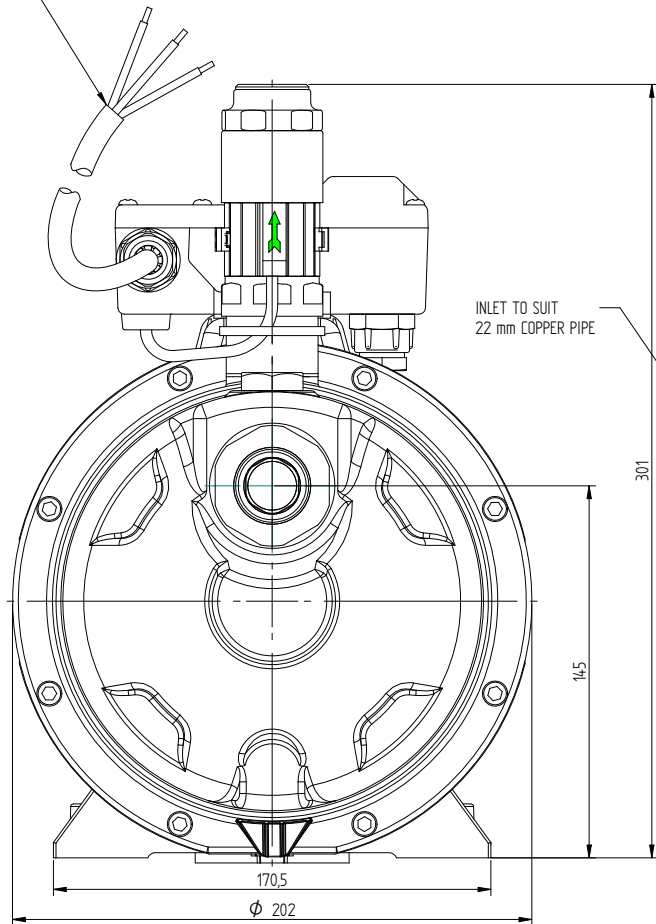

Stuart Turner Ltd reserves the right to amend specifications without notice.

Stuart Turner Ltd own the copyright within this document.  
The document may be printed for personal use only. The document  
must not be altered, reproduced or utilized in any way without  
written permission from Stuart Turner Ltd, Henley-on-Thames, Oxon, UK.

## GENERAL ARRANGEMENT OF A MONSOON EXTRA STANDARD 4.5 BAR SINGLE

W41056

DATE: 01/10/09