

# STUART TURNER



## Stainless Peripheral Pumps

### OPERATING INSTRUCTIONS

**Please leave this instruction booklet with the pump as it  
contains maintenance and safety information  
(Original Instructions)**

## MODELS

<b>Vertical Suction</b>
RG550-2

<b>INDEX</b> .....	<b>Page No</b>	.....	<b>Page No</b>
Application .....	2	Noise .....	9
Product Description .....	3	Commissioning .....	9
Limits of Application .....	4	Maintenance .....	11
Technical Specification .....	4	Trouble Shooting Guide .....	12
Siting of the Pump/Pipework .....	4	Environment Protection .....	12
Electrical Installation .....	6		

## IMPORTANT NOTES



- Please read these instructions fully before starting the installation:
- The installation must comply with the relevant water supply, electrical and building regulations and be installed by a competent person.
- If in doubt, consult Stuart Turner Ltd.
- This appliance is not intended for use by persons (including children) with reduced physical, sensory or mental capabilities, or lack of experience and knowledge, unless they have been given supervision or instruction concerning use of the appliance by a person responsible for their safety.  
Children should be supervised to ensure that they do not play with the appliance.

## APPLICATION

The range of stainless steel peripheral pumps is designed to pump clean fresh water. Other clean, non aggressive, non explosive liquids with similar characteristics to water may be pumped. Consult Stuart Turner for such applications.

The pumps can be used for pressure boosting, fluid transfer and distribution. They are suitable for flooded suction applications. Alternatively a maximum suction lift of 4.6 m is permitted when using a Stuart footvalve/strainer.

## WARNING AGAINST MISUSE



**This pump set must not be used for any other application without the written consent of Stuart Turner Limited. In particular, it must not be connected directly to the mains water supply, or used outside the conditions specified in the limits of application.**

## PRODUCT DESCRIPTION

### Motor:

Induction type, totally enclosed fan ventilated cooling\*, continuously rated\*, class 'F' insulation. Motors comply with IEC34-1. Single phase versions incorporate a permanent capacitor and integral auto resetting thermal overload protection.

The standard range of motors are suitable for a supply of 230V, 1 phase, 50Hz.

Optional motors are available on certain models to suit various voltages and frequencies (see technical specification for details).

\*Variations of rating and enclosure details can be found in the technical specification section.

### Pump

All models are close coupled to motor.

RG550-2 are of single stage, peripheral design, with vertical suction and discharge ports.

Standard pump materials of construction of major wetted parts are as follows: -

Model	Body	Impeller	Shaft	Mechanical Seal
All Variants	Stainless Steel	Stainless Steel	Stainless Steel	Nitrile/Carbon Ceramic/Stainless Steel

Other seal material options are available on certain models.

Cont.....

## LIMITS OF APPLICATION

Part No	Model	Supply	Max. Liquid Temp (°C)	Min. Liquid Temp (°C)	Max. Ambient Air Temp (°C)	Max. Suction Lift (m)	Max. Head (Pump Closed Valve (m))		Max. Viscosity		**Max. Working Pressure kPa (Bar)	Max. Inlet Head (m)		Max. No Starts/h
							50 Hz	60 Hz	(Redwood No. 1 Scale)	Centistokes		50 Hz	60 Hz	
46455	RG550-2	230/1/50	80	4	40	4.6*	40		50	9.5	600 (6)	21		60
46469	RG550-2	230/1/50	80	4	40	4.6*	40		50	9.5	600 (6)	21		60
46470	RG550-2	230/1/50	80	4	40	4.6*	40		50	9.5	600 (6)	21		60

\* With footvalve fitted.

\*\*Note: Max working pressure is the maximum pressure that can be applied to the pump internal casing under any installation conditions.

## TECHNICAL SPECIFICATION

Part No	Model	Supply	Nominal Watts Output (Motor)	Max Watts Consumed		Full Load (AMPS)		Enc. Rating	Duty Rating	Dimensions (mm)			Gross Weight (packed) Kg	Connections	
				50 Hz	60 Hz	50 Hz	60 Hz			L	W	H		Suction	Delivery
46455	RG550-2	230/1/50	300	455		2.0		IP44	Continuous (S1) @ 2.5 l/min & above	242	126	180	6.3	G¾ M	G¾ M
46469	RG550-2	230/1/50	300	455		2.0		IP44	Continuous (S1) @ 2.5 l/min & above	242	126	180	6.3	G¾ M	G¾ M
46470	RG550-2	230/1/50	300	455		2.0		IP44	Continuous (S1) @ 2.5 l/min & above	242	126	180	6.3	G¾ M	G¾ M

Stuart Turner reserve the right to amend the specification in line with its policy of continuous development of its products.

Note: For information on other voltages/frequencies which are not shown, consult any supplementary instruction sheet supplied, or the rating label attached to the pump.

## SITING OF THE PUMP/PIPEWORK

### WARNINGS:



- **Pump Location**  
If possible site the pump in a location where in the unlikely event of a liquid leak, any spillage is contained or routed to avoid electrics or areas sensitive to liquid damage.
- **Care should be taken to protect the pump from frost and freezing.**
- **Ensure pipework to and from pump is independently supported to prevent stress on the pump inlet and outlet branches.**
- **Do not fit a non-return valve, or devices which contain non-return valves, in the suction (inlet) pipework to the pump. Exceptions can be made in the case of suction lift installations when a footvalve is required.**



- **When a footvalve is required on installations that incorporate automatic pump control, it is recommended that a suitable pressure relief valve be fitted in the discharge (outlet) pipework from the pump.**
- **Do not run against a closed valve for periods longer than 5 minutes.**
- **Do not allow plastic pump parts to come into contact with oil or cellulose based paints, paint thinners or strippers, acid based descalents or aggressive cleaning agents.**
- **Do not introduce solder flux to pumps or pump parts manufactured from plastic. All solder joints should be completed and flux residues removed prior to pump connection.**
- **Always install isolating valves to both suction and delivery pipework.**
- **The motor casing can become very hot under normal operating conditions. Care should be taken to ensure it cannot be touched during operation.**

Site the pump in a dry, frost-free horizontal position where it cannot be sprayed with water and as close to the liquid source as possible.

The pump enclosure must be ventilated and there should be a minimum clearance of 80 mm between the pump and housing on all sides.

To prevent loss of pressure through pipework, use pipe size to match pump whenever possible, minimising 90° bends.

It must be ensured that storage capacity of the liquid supply is adequate for the flow rates required by the pump.

The pipework feeds to the storage tank should be of adequate size to ensure replenishment rate of tank is sufficient to meet the needs of the pump.

Isolating valves should be fitted in suction and delivery pipework to enable easy isolation and access to the pump.

When the pump is to be installed in areas where there is a risk of debris or scale build up within the system, it is recommended that the inlet pipework is fitted with an inline strainer.

### Pump Mounted Above Liquid Source (Suction Lift)

The pumps can be used in a suction lift installation providing the height of lift is within the limits specified in the limits of application section.

A footvalve and strainer must always be used and the suction pipework size should be 22 mm throughout.

Lay the suction piping over the shortest possible distance and ensure there is a constant rise from the liquid source to the pump. Any high spots will cause air pockets to form, reducing system efficiency.

Ensure all joints in suction pipework are completely airtight. Failure to comply will result in loss of prime.

The intake of the footvalve/strainer should be positioned such that it cannot be blocked with debris or silt that are frequently found in the bottom of sumps and wells.

Cont....

When a footvalve is installed on installations that incorporate automatic pump control, it is recommended that a suitable pressure relief valve be fitted in the discharge (outlet) pipework from the pump.

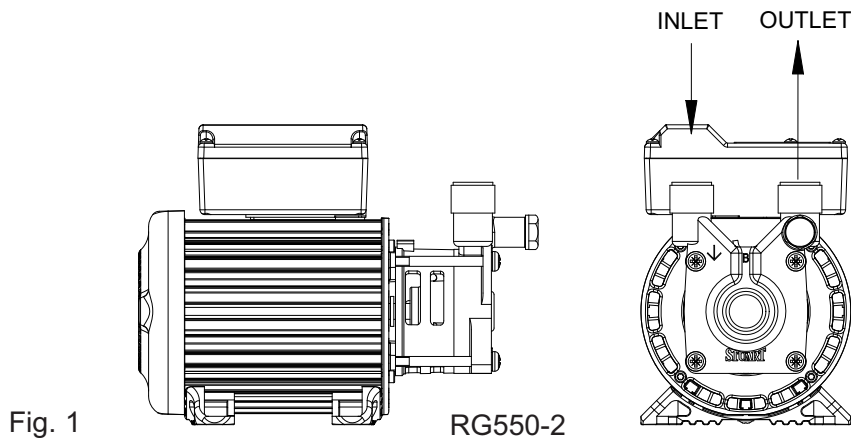

## ELECTRICAL INSTALLATION

### WARNINGS:



- The electrical installation must be carried out in accordance with the current national electrical regulations by a competent person.
- Before starting work on the electrical installation ensure the power supply is isolated.
- Where any of the pumps are installed in an area where there is a risk of water spillage it is recommended that a residual current circuit breaker having a rated current not exceeding 30 mA, be installed in the supply circuit. This may be part of a consumer unit or a separate unit.
- This appliance must be earthed.
- The motor and wiring must not be exposed to water.
- Do not allow the supply cord to contact hot surfaces, including the motor shell, pump body or pipework. The cord should be safely routed and secured by cable clips.

The standard single phase pumps are suitable for a supply of 230V, 1 Phase, 50Hz. Other voltages and frequencies are available on certain models and it is therefore very important to ensure the voltage and frequency on the pump rating plate matches the supply.

When installing a 230V, 1 phase, pump in the United Kingdom, means for disconnection must be incorporated in the fixed wiring according to the Wiring Rules. This can be done by permanently connecting the pump to the mains supply via a double pole switched, fused connection unit complying with BS 1363-4.

When installing a 110V, 1 phase pump it must be in accordance with the current electrical regulations that apply to the installation.

All motors exceeding 370 watt output should be provided with control equipment incorporating means for protection against overload.

The spur box (fused connection unit) or starter to which the pump is connected should be mounted in an easily accessible position and labelled if confusion is possible to allow easy isolation of the unit.

All pumps are continuously rated.

Cont....

## Earthing

This appliance must be earthed via the supply cord, which must be correctly connected to the earth point located in the terminal box.

Metallic pipework must have supplementary earth bonding where the continuity has been broken by flexible hoses or plastic components. Adjacent suction and delivery pipes should be fitted with earthing clamps to BS 951 and connected with earthing wire size 4 mm<sup>2</sup> (Fig. 3). A standard kit is available from Stuart Turner (Part No. 17044).

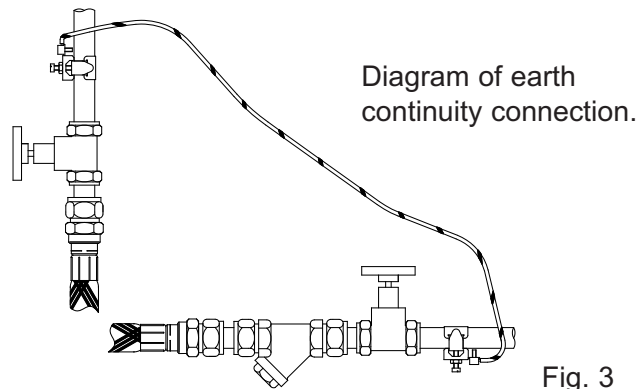

Fig. 3

Certain installations may require additional earthing arrangements such as equipotential bonding. Reference should be made to the relevant regulations concerning this subject to ensure compliance.

## Wiring

This product range must be permanently connected to fixed wiring and is provided with a set of terminals which allow the connection of a flexible supply cord.

Select a cord and fuse size based on the motor full load current and the surrounding conditions.

For information on cable fitting and connection, consult the wiring diagram and cable gland and supply cord fitting instructions.



**WARNING: This appliance must be earthed.**

## Fuses

The power cord must be sourced and supplied by the installer. Cable selection and fuse size should be based on the motor full load current and the surrounding conditions.

Cont...

## Cable Gland & Supply Cord Fitting Instructions (Single phase range)

The cable gland assembly Fig. 6 (items 1 & 2) provides the necessary protection against ingress of solid objects and moisture as well as providing cable retention.

Assembly instructions are as follows: -

1. Ensure selected cable sheath diameter is within the permitted range (6.5 to 9.5 mm).
2. Strip and prepare the cable sheath and insulators as shown in Fig. 4.
3. Disassemble cable gland as shown in Fig. 6 and insert cable into position ensuring 'O'-ring (item 1) is placed over the cable before the clamping insert (item 2) is tightened.
4. Consolidate the stranded conductor ends by twisting and shape the earth conductor as shown in Fig. 5 (item 3).
5. Remove earth terminal post clamping components and assemble as shown in Fig. 5 ensuring shaped conductor is orientated as shown and all strands of the conductor are clamped between the washers.
6. Insert and secure live and neutral conductors ensuring all conductor strands are clamped.
7. Confirm cable routing is as shown in Fig. 6 and assemble and secure terminal box lid.

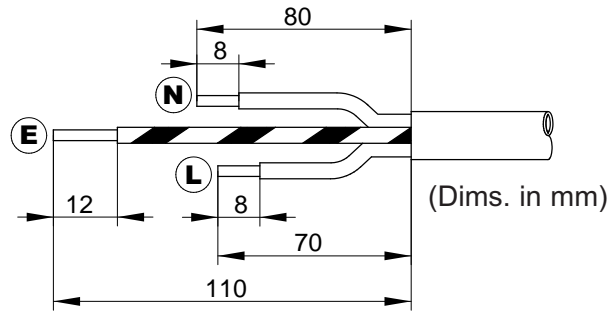

Fig. 4

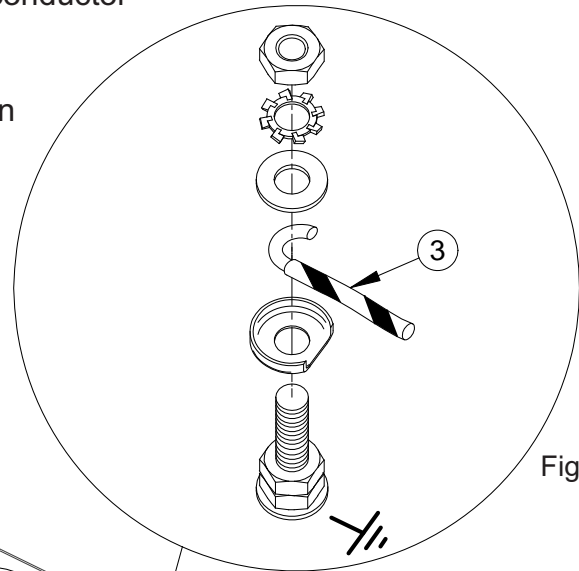

Fig. 5

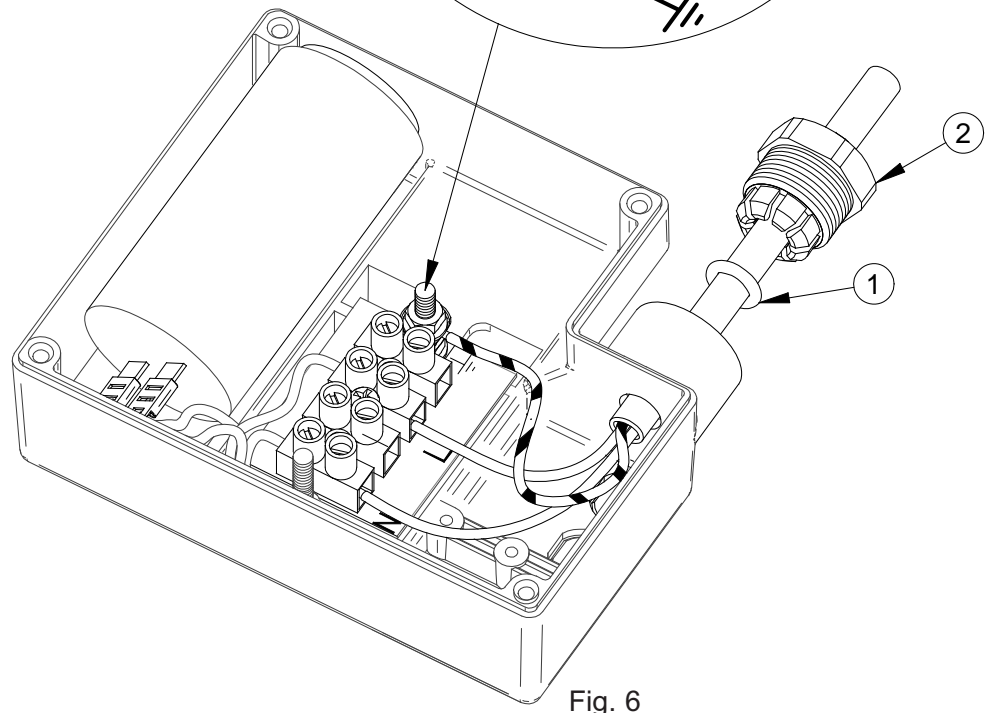

Fig. 6

## Wiring Diagrams



The internal wiring within the terminal box are routed and secured to ensure compliance with the electrical standard EN 60335-1. It is essential that any disturbance of this internal wiring is avoided and the factory routing and securing of all internal wiring is always maintained.

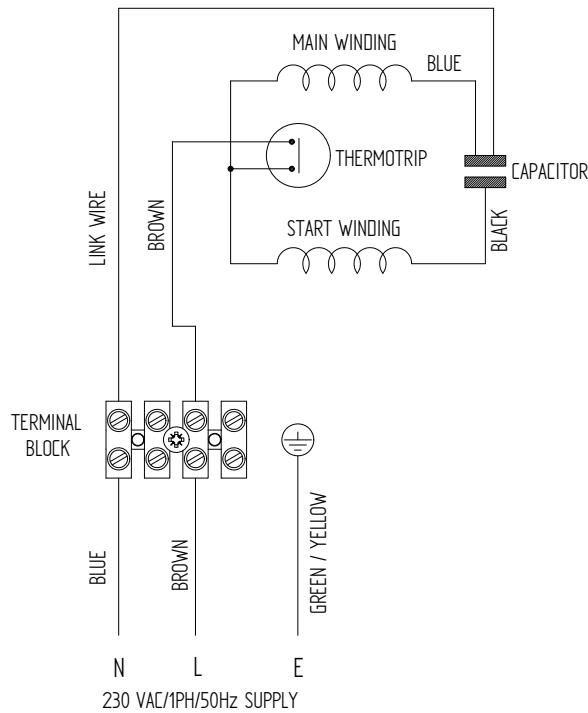

Fig. 10

## NOISE

The equivalent continuous A-weighted sound pressure level from the pumpset does not exceed 70 dB(A) at a distance of one metre.

## COMMISSIONING

### WARNINGS:



- The motor casing can become very hot under normal operating conditions, care should be taken to ensure it cannot be touched during operation.
- Do not run pump without guards and terminal box lid correctly fitted.
- The pump chamber must be full of liquid at all times. Seal damage will result if the pump runs dry.



#### 1. System Flushing

Some pumps incorporate plastic and rubber components that must not come into contact with solder flux, acid-based descalents or aggressive cleaning agents. The pipework system should be flushed out prior to the pump being connected, to ensure any contaminants/chemical residues and foreign bodies are removed from elsewhere in the system.



## 2. Liquid Supply

Always ensure that liquid storage capacity is adequate to meet the demand. Ensure the pump chamber is full of liquid before starting the pump. Failure to do this could result in seal damage. To ensure dry running does not occur the pumps must be primed as described in the priming section. Do not run pump dry.

3. Ensure electrical supply is compatible with the details that are stated on the pump rating plate. (The wrong voltage or frequency can be dangerous and may damage the pump.)

## 4. Priming

### a) Vertical suction models (flooded suction)

The pump must be primed (filled with liquid) before starting. Turn on liquid supply, prime and vent the pump by unscrewing the priming plug (Fig. 16) slowly until all air escapes and liquid emerges. Re-tighten the plug.

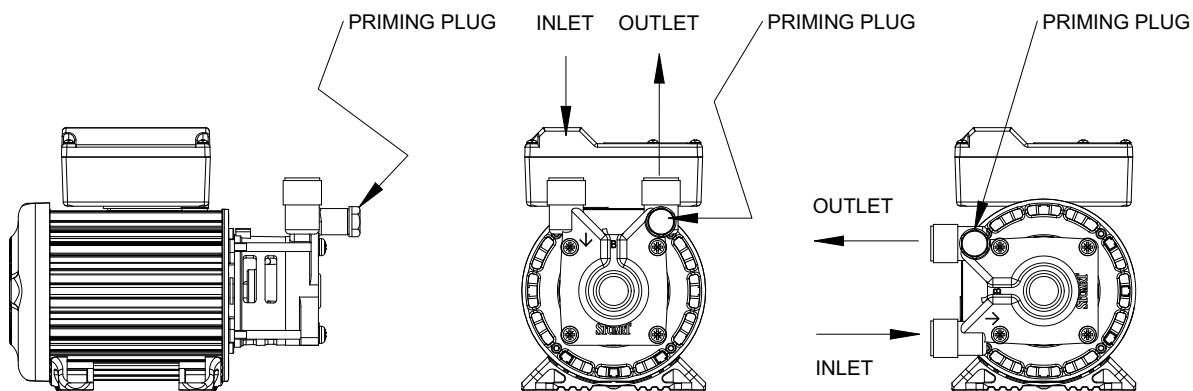

Fig. 16

RG550-2  
c/w Body Rotated  
(Special Build)

### b) All models (suction lift installation)

Prime the suction pipework and pump by filling with liquid via the pump discharge connection, or by filling the suction pipework before attaching to the pump, then fill the pump.

## 5. Starting

a) Switch on power to the pump which will now be operational.

b) Carefully check pump and pipework for leaks whilst pump running and stationary before leaving the installation unattended.

## For Further Technical Support

Note: When pumps are installed in another manufacturers original equipment, please contact the manufacturer for advice.

Phone the Stuart Turner Pump Assist team on 0844 98 000 97. Our staff are trained to help and advise you over the phone or arrange for a service engineer to call.

## MAINTENANCE

### WARNINGS:



- Care should be taken to protect the pump from frost and freezing.
- **Pump Location**  
If possible site the pump in a location where in the unlikely event of a liquid leak, any spillage is contained or routed to avoid electrics or areas sensitive to water damage.

1. No routine maintenance is required but provision should be made for easy access to the pump to allow for repairs due to normal wear and tear.
2. Disconnect electrical supply before working on pump.
3. Turn off liquid supplies to the pump and release pressure by opening outlets before attempting maintenance.
4. If the installation is fitted with a footvalve and strainer or inline suction strainer, the strainer must be cleaned as necessary to ensure the pump has unrestricted flow.
5. After maintenance is completed, refer to commissioning section for instructions on restarting pump.

### Cleaners, Disinfectants and Descalents



On installations where chemical disinfectants or descalents are periodically used, the compatibility of the chemical solution regarding the pump must be considered.

Acid based descalents and aggressive cleaning agents must not come into contact with the pump. The pump must be removed from the system prior to the use of these products. The system should be flushed to remove all chemicals before the pump is re-connected.

If in any doubt as to the suitability of the chemical solutions refer to Stuart Turner Ltd.

### STORAGE

If this product is not installed immediately on receipt, store in a dry, frost and vibration free location in its original packaging.

## TROUBLE SHOOTING GUIDE

Symptoms	Probable Cause	Recommended Action
Pump will not start.	<p>Electrical supply.</p> <p>Starter thermal overload tripped.</p> <p>Integral motor thermotrip activated.</p>	<p>Check power to motor. Check the circuit breaker is set. Check the correct fuse is being used.</p> <p>Check overload in starter (if applicable). Investigate cause of problem.</p> <p>Wait for thermotrip to cool and auto-reset. Investigate cause of problem.</p>
Pump runs, but no liquid.	<p>Air locked.</p> <p>No liquid supply.</p> <p>Connections reversed.</p> <p>No flooded suction.</p>	<p>Bleed pipework and pump to clear air.</p> <p>Check the supply valves are turned on. Check outlet not restricted or blocked.</p> <p>Check liquid connections are on the right way round.</p> <p>Check the pump has a flooded suction and is primed.</p> <p>If a suction lift exists fit a Stuart footvalve/strainer and ensure suction is airtight. Prime the pump and suction pipe (see commissioning section).</p>

## ENVIRONMENT PROTECTION

Your appliance contains valuable materials which can be recovered or recycled.

At the end of the products' useful life, please leave it at an appropriate local civic waste collection point.

## **YOUR 1 YEAR GUARANTEE**

Stuart Pumps are guaranteed by Stuart Turner Limited to be free from defects in materials or workmanship for the applicable guarantee period from the date of purchase. The applicable guarantee period is stated in the installation booklet supplied with the pump. Within the guarantee period we will repair, free of charge, any defects in the pump resulting from faults in material or workmanship, repairing, exchanging parts or exchanging the whole unit as we may reasonably decide.

Not covered by this guarantee: Damage arising from incorrect installation, improper use, unauthorised repair, normal wear and tear and defects which have a negligible effect on the value or operation of the pump.

Reasonable evidence must be supplied that the pump has been purchased within the applicable guarantee period prior to the date of claim (such as proof of purchase or the pump serial number).

This guarantee is in addition to your statutory rights as a consumer. If you are in any doubt as to these rights, please contact your local Trading Standards Department or Citizen's Advice Bureau.

In the event of a claim please telephone Stuart Turner Limited on 0844 980 0097 or return your pump and flexible hoses with accessories removed, plugs, pipes etc. If you have any doubt about removing a pump, please consult a professional.

Proof of purchase should accompany the returned pump to avoid delay in investigation and dealing with your claim.

## NOTES

## NOTES



## DECLARATION OF CONFORMITY

**2006/42/EC**

BS EN ISO 12100-1, BS EN ISO 12100-2, BS EN 809

**2006/95/EC**

BS EN 60335-1, BS EN 60335-2-41, EN 50366

**2004/108/EC**

BS EN 55014-1, BS EN 55014-2, BS EN 55022, BS EN 61000-3-2, BS EN 61000-3-3,  
BS EN 61000-4-2, BS EN 61000-4-3, BS EN 61000-4-4, BS EN 61000-4-5, BS EN 61000-4-6,  
BS EN 61000-4-11

IT IS HEREBY CERTIFIED THAT THE STUART ELECTRIC MOTOR DRIVEN PUMP AS  
SERIAL NUMBER BELOW, COMPLIES WITH THE ESSENTIAL REQUIREMENTS OF THE  
ABOVE E.E.C. DIRECTIVES.



RESPONSIBLE PERSON  
AND MANUFACTURER

STUART TURNER LIMITED  
HENLEY-ON-THAMES, OXFORDSHIRE  
RG9 2AD ENGLAND.

Signed ..... 

Customer Relationship Manager

Stuart Turner are an approved company to BS EN ISO 9001:2000

# STUART TURNER

Stuart Turner Ltd, Henley-on-Thames, Oxfordshire RG9 2AD ENGLAND

Tel: +44 (0) 1491 572655, Fax: +44 (0) 1491 573704

email: [pumps@stuart-turner.co.uk](mailto:pumps@stuart-turner.co.uk) web: [www.stuart-turner.co.uk](http://www.stuart-turner.co.uk)

V.A.T. REG. No. 199 0987 92. Registered in England No. 88368. Registered Office: Market Place, Henley-on-Thames

Issue No. 1510/4-13

Pt. No. 17730