

# STUART TURNER



## SELF PRIMING JET PUMPS

### OPERATING INSTRUCTIONS

**Please leave this instruction booklet with the pump as it  
contains maintenance and safety information  
(Original Instructions)**

**MODELS:**        Jet 40  
                      Jet 90

<b>INDEX</b> .....	<b>Page No</b>
Application .....	2
Product Description .....	3
Limits of Application .....	3
Technical Specification .....	3
Pump Connections .....	4
Siting of the Pump/Pipework .....	5
Electrical Installation .....	7
Noise .....	10
Commissioning .....	10
Maintenance .....	12
Storage .....	13
Trouble Shooting Guide .....	13
Environment Protection .....	14

## **IMPORTANT NOTES**



- **Please read these instructions fully before starting the installation:**
- **The installation must comply with the relevant water supply, and building regulations and be installed by a competent person.**
- **If in doubt, consult Stuart Turner Ltd.**

## **APPLICATION**

The Jet range of pumps is designed to pump clean fresh water. Other clean, non aggressive, non explosive liquids with similar characteristics to water may be pumped, consult Stuart Turner for such applications.

The pumps can be used for applications such as water transfer and distribution, pressure boosting and irrigation. The pump can be used for portable applications and is also suitable for self-priming (after initial priming) installations using the optional suction hose/footvalve assembly.



### **WARNING AGAINST MISUSE**

- **This pump set must not be used for any other application without the written consent of Stuart Turner Limited and, in particular, must not be connected directly to the mains water supply or used outside the conditions specified in the limits of application.**
- **This appliance is not intended for use by persons (including children) with reduced physical, sensory or mental capabilities, or lack of experience and knowledge, unless they have been given supervision or instruction concerning use of the appliance by a person responsible for their safety.**  
**Children should be supervised to ensure that they do not play with the appliance.**

## PRODUCT DESCRIPTION

### Motor

Induction type, totally enclosed fan ventilated cooling, continuously rated, class 'B' insulation, permanent capacitor, IP 44 enclosure. Motors are fitted with an integral auto-resetting thermal overload, comply with IEC 34-1 and are suitable for a supply of 230V, 1 phase, 50Hz.

### Pump

Close coupled, single stage, end suction configuration and of centrifugal design with integral Jet injector.

Standard pump materials of construction of major wetted parts are as follows:-

Model	Body	Impeller	Shaft	Injector	Diffuser	Mechanical Seal
All	Polypropylene	Noryl	Stainless Steel	Noryl	Noryl	Nitrile/carbon Ceramic/Stainless Steel

## LIMITS OF APPLICATION

Model	Max. Water Temp (°C)	Min. Water Temp (°C)	Max. Ambient Air Temp (°C)	Max. Suction Lift (m)	Max. Head (Pump Closed Valve) (m)	Max. Viscosity		*Max. Working Pressure kPa (bar)	Max. Inlet Head (m)	Max. No Starts/h
						(Redwood No. 1 Scale)	Centistokes			
40	35	4	40	7	36.5	50	9.5	600 (6)	5	30
90	35	4	40	7	51	50	9.5	600 (6)	5	30

\*Note: Max working pressure is the maximum pressure that can be applied to the pump internal casing under any installation conditions.

## TECHNICAL SPECIFICATION

Model	Supply	Max. Watts Consumed	Nominal Watts Output (Motor)	Full Load Current (AMPS)	Enc. Rating	Duty Rating	Dims. (mm)			Gross Weight (packed) Kg	No of Pump Stages
							L	W	H		
40	230/1/50	490	340	2.4	IP44	Continuous	358	209	225	7.2	1
90	230/1/50	1200	840	5.2	IP44	Continuous	400	230	230	12.4	1

Stuart Turner reserve the right to amend the specification in line with its policy of continuous development of its products.

Note: For information on other voltages/frequencies which are not shown, consult any supplementary instruction sheet supplied, or the rating label attached to the pump.

Cont....

## PUMP CONNECTIONS

Model	Inlet	Outlet
Jet 40	G1 Male	G1 Male
Jet 90	G1 Female	G1 Female

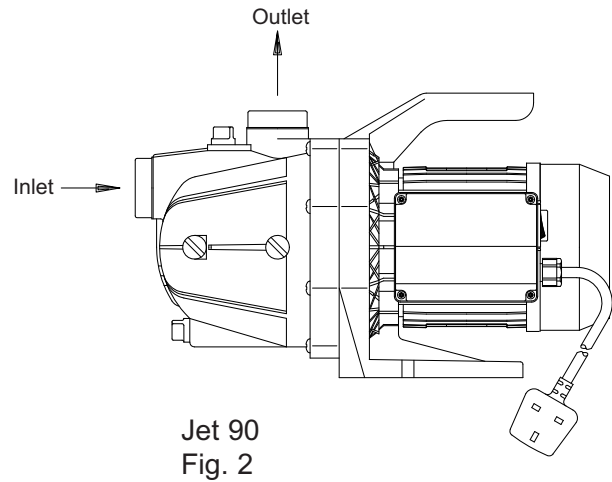
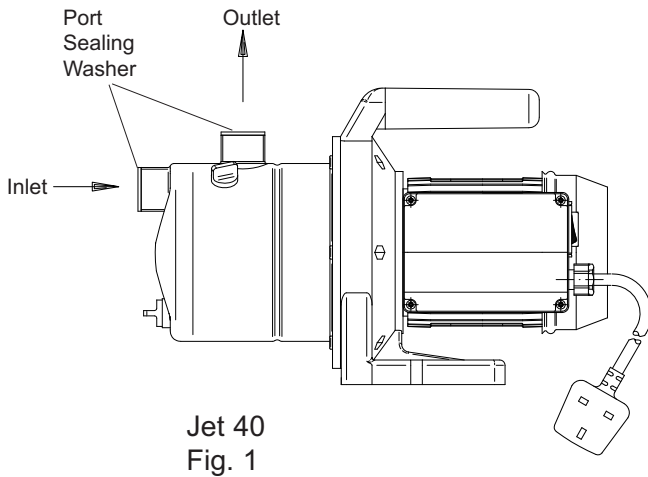

### Jet 40

The inlet and outlet ports of this pump range are supplied with factory fitted port sealing washers (Fig. 1).

This provides the option of sealing the connecting fittings on the end of the pump threads with the aid of a flat sealing washer (not provided).

The other sealing option is via the thread by applying thread sealant tape or adhesive.

### Optional Extra Pump Connections

A discharge hose elbow fitting and suction hose fitting, complete with hose and footvalve and strainer are available as optional extras. The part numbers are as follows:

- G1 discharge hose elbow assembly . . . . . 26881
- Suction hose assembly, 7 metres including footvalve/strainer . . . . . 26880

It is important that the optional suction hose assembly is always used on suction lift installations. For details and assembly order of these fittings see Figs. 3 & 4.

Cont....

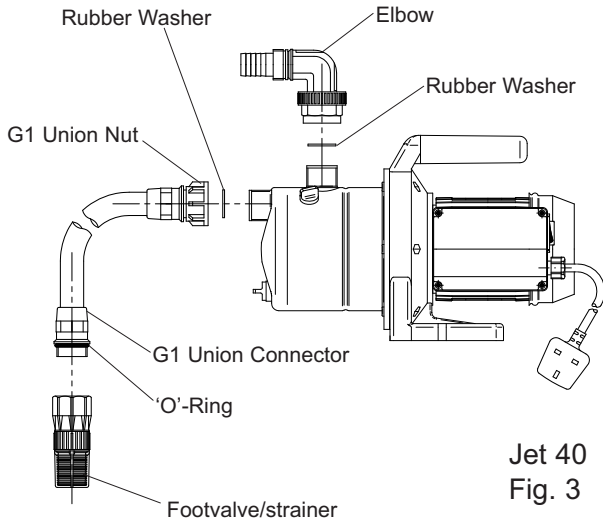

Jet 40  
Fig. 3

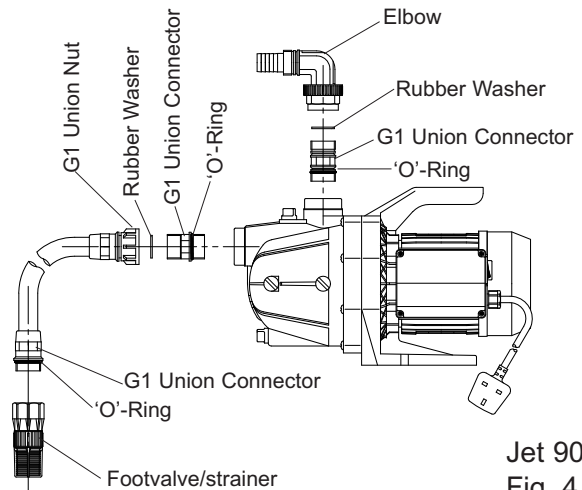

Jet 90  
Fig. 4

The G1 union connectors (see above) utilise an 'O'-ring seal between the union and the pump. These unions should only be tightened 'hand tight' for a good seal to be obtained.

## SITING OF PUMP/PIPEWORK

### WARNINGS:



- **Pump Location**  
If possible site the pump in a location where in the unlikely event of a water leak, any spillage is contained or routed to avoid electrics or areas sensitive to water damage.
- Care should be taken to protect the pump from frost and freezing.
- Ensure pipework to and from pump is independently supported to prevent stress on the pump inlet and outlet branches.
- Do not fit a non-return valve, or devices which contain non-return valves, in the suction (inlet) pipework to the pump. Exceptions can be made in the case of suction lift installations when a footvalve is required.
- Always install isolating valves to both suction and delivery pipework.
- When a footvalve is required on installations that incorporate automatic pump control, it is recommended that a suitable pressure relief valve be fitted in the discharge (outlet) pipework from the pump.
- Do not run against a closed valve for periods longer than 5 minutes.
- Do not allow plastic pump parts to come into contact with oil or cellulose based paints, paint thinners or strippers, acid based descalents or aggressive cleaning agents.
- Do not introduce solder flux to pumps or pump parts manufactured from plastic. All solder joints should be completed and flux residues removed prior to pump connection.
- The motor casing can become very hot under normal operating conditions. Care should be taken to ensure it cannot be touched during operation.
- Ensure the pump cannot be subjected to freezing conditions as damage may result.

## General

Locate the pump in a frost free horizontal position where it cannot be sprayed with water and as close to the water source as possible.

The pump is suitable for use as a portable unit and is provided with a carrying handle for this purpose.

If the pump is to be installed in a permanent installation, it should be located in a purpose built housing that must be capable of providing protection against rain, frost and flooding. The enclosure must be ventilated and there should be a minimum clearance of 80 mm between pump and housing on all sides.

Care must be taken when mounting the pump that any noise is not amplified through loose panels, pipework or other mounting medium. Noise transmission in pipework can be reduced by fitting flexible hoses to pump inlet and outlet ports and by placing the pump on anti-vibration mounting pads. Resilient mounting pads and flexible hoses are available separately as optional extras, contact Stuart Turner for further details.

To prevent loss of pressure through pipework, use pipe size to match pump (25 mm diameter) whenever possible, minimising 90° bends.

When making pipework connections to the Jet 90, use plastic fittings for direct connection to pump.

The pipework feeds to the storage tank should be of adequate size to ensure replenishment rate of tanks is sufficient to meet the needs of the pump.

Isolating valves should be fitted in suction and delivery pipework to enable easy isolation and access to the pump. When pump is to be installed in areas where there is risk of debris or scale build up within the system, it is recommended that the inlet pipework is fitted with an inline strainer.

## Pump Mounted Below Water Source (Flooded Suction Installation)

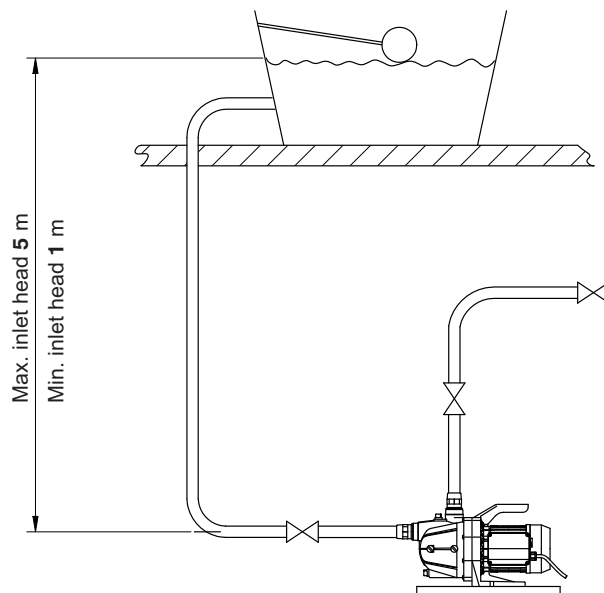

Fig. 5

Diagram showing typical flooded suction installation.

Before deciding where to locate the pump check to ensure the static inlet head (Fig. 5) meets the minimum requirement of 1 metre and does not exceed the maximum requirement of 5 metres.

## Pump Mounted Above Water Source (Suction Lift Installation)

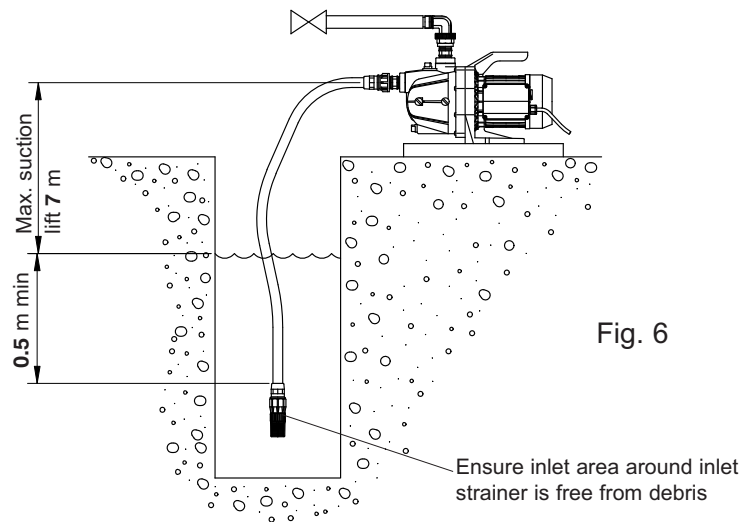

Diagram showing typical suction lift installation.

The pumps can be used in a suction lift installation providing the height of lift is within maximum permitted (Fig. 6).

It is important that the optional suction hose assembly is always used for suction lift installations.

Lay the suction piping over the shortest possible distance and ensure there is a constant rise from the water source to the pump. Any high spots will cause air pockets to form reducing system efficiency.

Ensure all joints in suction pipework are completely airtight. Failure to comply will result in loss of prime.

The intake of the footvalve/strainer should be positioned so that it cannot be blocked with debris or silt that are frequently found in the bottom of sumps and wells.

When a footvalve is installed on installations that incorporate automatic pump control, it is recommended that a suitable pressure relief valve be fitted in the discharge (outlet) pipework from the pump.

### Self Priming

Jet 40 and 90 pumps are capable of self priming the suction hose assembly provided the optional suction hose is always used for this type of installation.

## **ELECTRICAL INSTALLATION**

### **WARNINGS:**



- **The electrical installation must be carried out in accordance with the current national electrical regulations and installed by a competent person.**
- **In the interests of electrical safety a 30 mA. residual current device (R.C.D.) should be installed in the supply circuit. This may be part of a consumer unit or a separate unit.**
- **Before starting work on the electrical installation ensure the power supply is isolated.**
- **This appliance must be earthed.**
- **The motor and wiring must not be exposed to water.**

The standard pumps are suitable for a supply of 230V, 1 Phase, 50Hz. Other voltages and frequencies are available on certain models and it is therefore very important to ensure the voltage and frequency on the pump rating plate matches the supply.

The pumps are rated for continuous use.

All motors exceeding 370 watt output should be provided with control equipment incorporating means for protection against motor overload.

The pump is fitted with an integral on/off switch which is located on the pump terminal box (Figs. 9 & 10).

## Earthing

This appliance must be earthed via the supply cord.

Copper or metallic pipework must have supplementary earth bonding where the continuity has been broken by flexible hoses or plastic components. Adjacent suction and delivery pipes should be fitted with earthing clamps to BS 951 and connected with earthing wire size 4 mm<sup>2</sup> (Fig. 7). A standard kit is available from Stuart Turner (Part No. 17044).

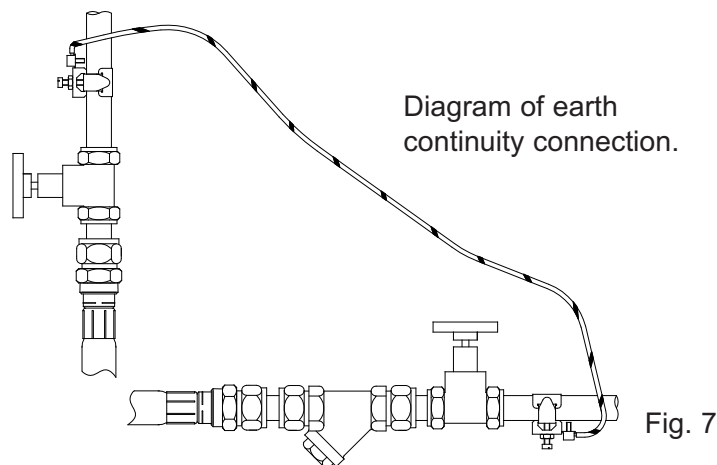

Certain installations may require additional earthing requirements such as supplementary equipotential bonding. Reference should be made to the relevant regulations concerning this subject to ensure compliance.

## Electrical Connection

The pump is provided with a factory fitted supply cord and plug. This must be connected to the mains supply via a 13 Amp double pole switched, socket outlet in compliance with BS 1363-2.

The socket outlet should be mounted in an easily accessible position and should be labelled if confusion is possible, to allow easy identification of the pump isolating switch.

## Wiring

**The moulded plug fitted to this appliance is not waterproof - keep dry.**

The supply cord is factory fitted with a moulded plug incorporating a fuse, the value of which is indicated on the pin face of the plug. Should the fuse need to be replaced, an ASTA approved BS 1362 fuse must be used of the same rating, marked thus, . If the fuse cover is detachable, never use the plug with the cover omitted. If a replacement fuse cover is required, ensure it is of the same colour as that visible on the pin face of the plug (i.e. red or orange).

If the plug supplied is not suitable for your socket outlet, it should be cut off and destroyed.



**WARNING: A plug with bared flexible cords is hazardous if engaged in a live socket outlet.**

The end of the flexible cord should be suitably prepared and correct plug fitted, as follows:

The wires in this mains lead (supply cord) are coloured in accordance with the following code:

Green & Yellow: Earth                      Blue: Neutral                      Brown: Live

As these colours may not correspond with the coloured markings identifying the terminals in your plug, proceed as follows:

The wire which is coloured green and yellow must be connected to the terminal in the plug which is marked with the letter 'E' or by the earth symbol  $\oplus$  or coloured green or green and yellow.

The wire which is coloured Blue must be connected to the terminal which is marked with the letter 'N' or coloured black or blue.

The wire which is coloured brown must be connected to the terminal which is marked with the letter 'L' or coloured brown or red.

### Wiring Diagram



**The supply cord and internal wiring within the terminal box are routed and secured to ensure compliance with the electrical standard EN 60335-1. It is essential that any disturbance of this internal wiring is avoided and the factory routing and securing of all internal wiring is always maintained.**

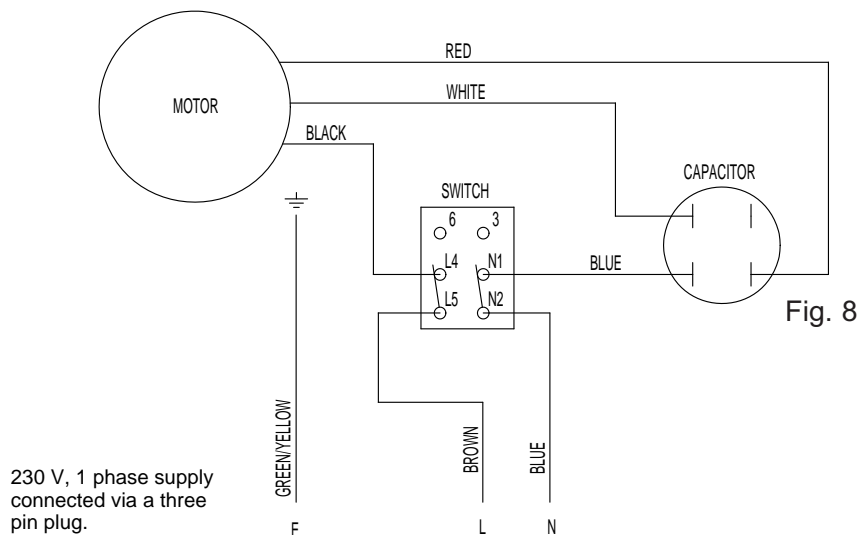

### Fuses

Important: The plug must be fitted with the following fuse size;

Jet 40: 13 Amp

Jet 90: 13 Amp

## Supply Cord Replacement

If the supply cord is to be changed or is damaged, it must be replaced with a special cord assembly available from Stuart Turner or one of their approved repairers.

On disassembly note the cord retention and routing system. Reassemble to the same pattern.

For information on cable fitting and connection, consult the wiring diagram and cable fitting instructions.

## Cable Fitting Instructions

1. Isolate pump from electrical supply.
2. Remove terminal box cover.
3. Loosen cable gland nut.
4. Remove cable connectors from switch terminals L5 and N2.
5. Remove earth connection.
6. Fit new cable in reverse order of above steps 1 to 5.
7. To ensure terminal box rubber gasket is located in correct position upon re-assembly, fit gasket to terminal box first, then locate terminal box cover and secure.

## Supply Cord Extension

The pumps are fitted with a supply cord suitable for outdoor use. Cord specification is as follows:-

HO7RN-F3 G 1.0 mm<sup>2</sup> - 10 Amp rating.

If the supply cord is to be extended, a cord of the same specification should be used. If the installation is outdoors then any connectors or junction boxes must be specifically suited for outdoor use and installed in accordance with the manufacturers instructions.

Any cable routed underground must be protected to local standards.

## **NOISE**

The equivalent continuous A-weighted sound pressure level at a distance of 1 metre from the pumpset does not exceed 76 dB(A) Jet 40

81 dB(A) Jet 90.

## **COMMISSIONING**

### **WARNINGS:**



- **The motor casing can become very hot under normal operating conditions, care should be taken to ensure it cannot be touched during operation.**
- **Do not run pump without guards and terminal box lid correctly fitted.**
- **Care should be taken to protect the pump from freezing.**
- **The pump chamber must be full of water at all times. Seal damage will result if the pump runs dry.**



1. System Flushing  
The pump incorporates some plastic components that must not come into contact with solder flux, acid-based descalents or aggressive cleaning agents. The pipework system should be flushed out prior to the pump being connected to ensure any contaminants/chemical residues and foreign bodies are removed from elsewhere in the system.



## 2. Water Supply

Always ensure that water storage capacity is adequate to meet the demand. Ensure the pump chamber is full of water before starting the pump. Failure to do this could result in seal damage. To ensure dry running does not occur the pump must be primed as described in priming section. **Do not run pump dry.**

3. Ensure electrical supply is compatible with the details that are stated on the pump rating plate. (The wrong voltage or frequency can be dangerous and may damage the pump.)

## 4. Priming

### a) Flooded suction installation

The pump must be primed (filled with water) before starting. Turn on water supply, prime and vent the pump by unscrewing the priming plug (Figs. 9 & 10) slowly until all air escapes and water emerges. Re-tighten plug.

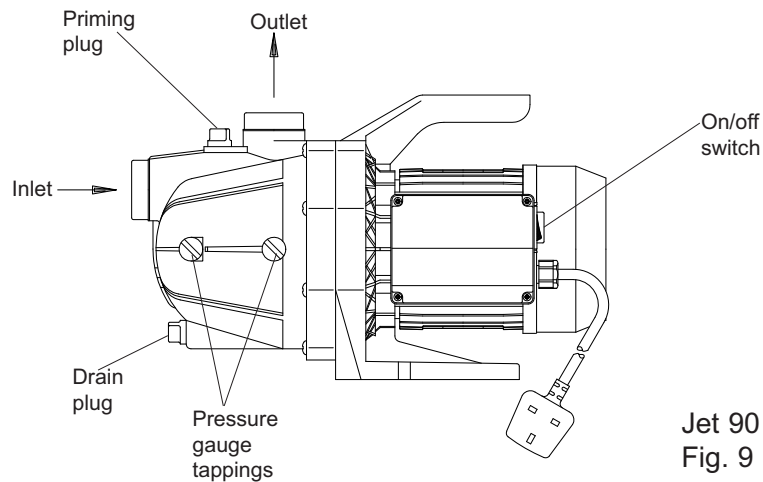

Jet 90  
Fig. 9

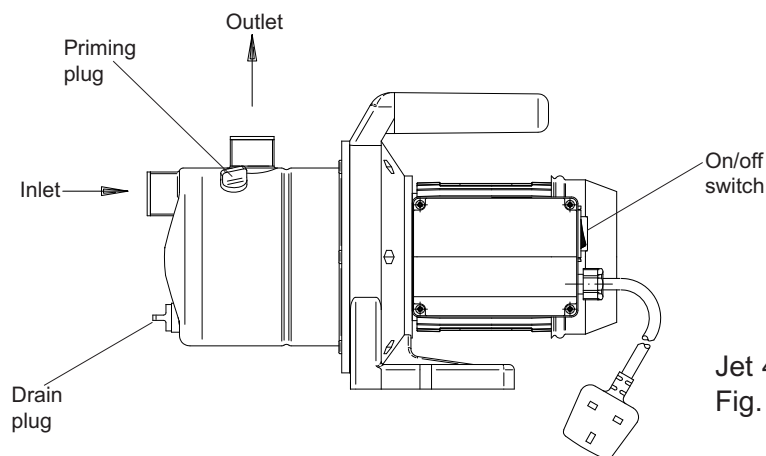

Jet 40  
Fig. 10

Cont....

b) Suction lift installation

It is important that the optional suction hose assembly is always used for this application.

A footvalve and strainer must be fitted to the end of the inlet pipework and is included with the optional hose assembly.

Prime the suction pipework by filling with water before connecting to the pump. Prime the pump by removing the priming plug (Figs. 9 & 10) slowly filling the pump body with water whilst allowing the air to escape. Replace the plug.

c) Suction lift installation, self priming of suction hose.

This pump is capable of self priming the suction hose with water on installation. It is important that the optional suction hose assembly is always used for this application. First ensure both suction and delivery hose connections are airtight. Remove the priming plug (Figs. 9 & 10) and slowly fill the pump body with water, whilst allowing the air to escape. Replace the plug.

Ensure the suction hose is fully submerged in the water source and the delivery hose is open to enable the pump to vent air. Turn on the electricity supply and turn on switch located on the pump (Figs. 9 & 10). The pump will start and begin to prime the suction pipework. The priming procedure may need to be repeated if pump does not prime within 5 minutes of starting.

Note: The amount of time required for priming will vary dependent on the height of the suction lift.

Once the system has been initially primed the footvalve/strainer will ensure the pump and pipework remains primed.

5. Starting The Pump

Turn on the electrical supply to the pump which will now be operational.

Note: There is an integral on/off switch mounted on the pump (Figs. 9 & 10) which must be turned to the on position.

Carefully check pump and pipework for leaks whilst pump running and stationary before leaving the installation unattended.

For Further Technical Support

Phone the Stuart Turner Pump Assist team on 0844 98 000 97. Our staff are trained to help and advise you over the phone or arrange for a service engineer to call.

Note: When pumps are installed in OEM equipment, please contact the OEM manufacturer for advice.

**MAINTENANCE**

**WARNINGS:**



- **Care should be taken to protect the pump from frost and freezing.**
- **Pump Location**  
**If possible site the pump in a location where in the unlikely event of a water leak, any spillage is contained or routed to avoid electrics or areas sensitive to water damage.**

1. No routine maintenance is required but provision should be made for easy access to the pump to allow for repairs due to normal wear and tear.
2. Disconnect electrical supply before working on pump.

3. Turn off water supplies to the pump and release pressure by opening outlets before attempting maintenance.
4. If the installation is fitted with a footvalve and strainer or inline suction strainer, the strainer must be cleaned as necessary to ensure the pump has unrestricted flow.
5. After maintenance is completed, refer to commissioning section for instructions on restarting pump.

### Cleaners, Disinfectants and Descalents



On installations where chemical disinfectants or descalents are periodically used, the compatibility of the chemical solution regarding the pump must be considered.

Acid based descalents and aggressive cleaning agents must not come into contact with the pump. The pump must be removed from the system prior to the use of these products. The system should be flushed to remove all chemicals before the pump is re-connected.

If in any doubt as to the suitability of the chemical solutions refer to Stuart Turner Ltd.

### **STORAGE**

If this product is not installed immediately on receipt, ensure that it is stored in a dry, frost and vibration free location in its original packaging.

### **TROUBLE SHOOTING GUIDE**

Symptoms	Probable Cause	Recommended Action
Pump will not start.	<p>Inlet filter/strainer blocked (if fitted).</p> <p>Electrical supply.</p> <p>Pump run on hot water which has caused the integral motor thermotrip to activate.</p> <p>Integral motor thermotrip activated.</p> <p>Integral on/off switch in off position.</p>	<p>Remove and clean filter gauze/strainer.</p> <p>Check all electrical switches are on. Is the correct fuse fitted? Is the circuit breaker set?</p> <p>Wait for thermotrip to cool an auto-reset. Check water temperature.</p> <p>Wait for thermotrip to cool and auto-reset. Investigate cause of problem.</p> <p>Switch to on position.</p>
Pump runs, but no water.	<p>Pump air locked.</p> <p>Water supply low.</p> <p>Blocked suction pipe.</p> <p>Air bubbles in suction pipe.</p>	<p>Remove priming plug, fill with water. Refit plug.</p> <p>Check water level in the supply tank or well and all stopcocks are open. Check outlet not restricted or blocked.</p> <p>Clean footvalve/strainer.</p> <p>Check connections are all airtight.</p>
Pump runs but no water on suction lift installation.	<p>Lack of priming water.</p> <p>Insufficient time allowed for priming to be completed.</p>	<p>Prime pump casing.</p> <p>Amount of time taken to prime suction pipe will vary dependent upon model selected and suction lift height. After 5 minutes repeat priming procedure.</p>

## **ENVIRONMENT PROTECTION**

Your appliance contains valuable materials which can be recovered or recycled.

At the end of the products' useful life, please leave it at an appropriate local civic waste collection point.

## **YOUR 1 YEAR GUARANTEE**

Stuart Pumps are guaranteed by Stuart Turner Limited to be free from defects in materials or workmanship for the applicable guarantee period from the date of purchase. The applicable guarantee period is stated in the installation booklet supplied with the pump. Within the guarantee period we will repair, free of charge, any defects in the pump resulting from faults in material or workmanship, repairing, exchanging parts or exchanging the whole unit as we may reasonably decide.

Not covered by this guarantee: Damage arising from incorrect installation, improper use, unauthorised repair, normal wear and tear and defects which have a negligible effect on the value or operation of the pump.

Reasonable evidence must be supplied that the pump has been purchased within the applicable guarantee period prior to the date of claim (such as proof of purchase or the pump serial number).

This guarantee is in addition to your statutory rights as a consumer. If you are in any doubt as to these rights, please contact your local Trading Standards Department or Citizen's Advice Bureau.

In the event of a claim please telephone Stuart Turner Limited on 0844 980 0097 or return your pump and flexible hoses with accessories removed, plugs, pipes etc. If you have any doubt about removing a pump, please consult a professional.

Proof of purchase should accompany the returned pump to avoid delay in investigation and dealing with your claim.

## NOTES



## DECLARATION OF CONFORMITY

**2006/42/EC**

BS EN ISO 12100-1, BS EN ISO 12100-2, BS EN 809

**2006/95/EC**

BS EN 60335-1, BS EN 60335-2-41, EN 50366

**2004/108/EC**

BS EN 55014-1, BS EN 55014-2, BS EN 55022, BS EN 61000-3-2, BS EN 61000-3-3,  
BS EN 61000-4-2, BS EN 61000-4-3, BS EN 61000-4-4, BS EN 61000-4-5, BS EN 61000-4-6,  
BS EN 61000-4-11

**2000/14/EC**

IT IS HEREBY CERTIFIED THAT THE STUART ELECTRIC MOTOR DRIVEN PUMP AS  
SERIAL NUMBER BELOW, COMPLIES WITH THE ESSENTIAL REQUIREMENTS OF THE  
ABOVE E.E.C. DIRECTIVES.



RESPONSIBLE PERSON  
AND MANUFACTURER

STUART TURNER LIMITED  
HENLEY-ON-THAMES, OXFORDSHIRE  
RG9 2AD ENGLAND.

Signed .....

Customer Relationship Manager

Stuart Turner are an approved company to BS EN ISO 9001:2000

# STUART TURNER

Stuart Turner Ltd, Henley-on-Thames, Oxfordshire RG9 2AD ENGLAND

Tel: +44 (0) 1491 572655, Fax: +44 (0) 1491 573704

email: [pumps@stuart-turner.co.uk](mailto:pumps@stuart-turner.co.uk) web: [www.stuart-turner.co.uk](http://www.stuart-turner.co.uk)

V.A.T. REG. No. 199 0987 92. Registered in England No. 88368. Registered Office: Market Place, Henley-on-Thames