

STUART TURNER LTD HENLEY-ON-THAMES.

THIRD ANGLE PROJECTION

DIMENSIONS IN MILLIMETRES

MODEL	DIMENSION			
	A	B	C	D
T6-2	326	77.5	107.5	137
T12-2	350	101.5	131.5	161

SCRAP VIEW ON ARROW X
(UNDERSIDE OF BASE.)
MOUNTING FOOT DETAILS.

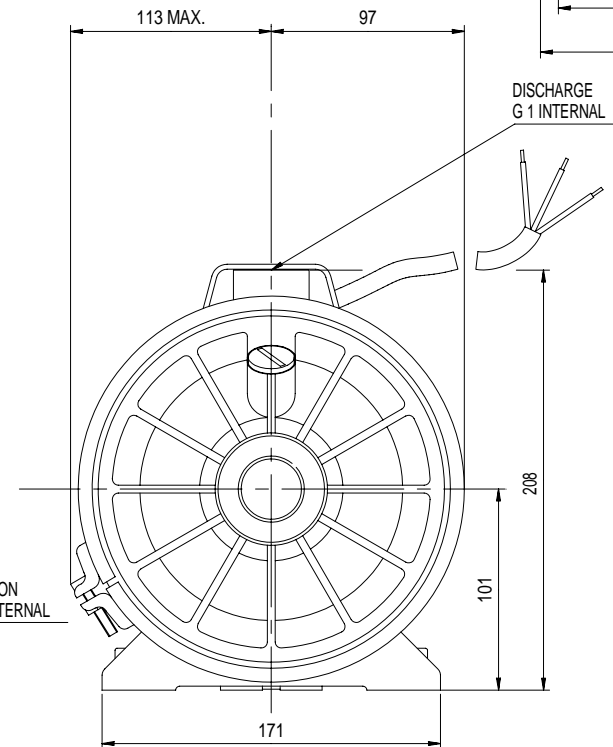
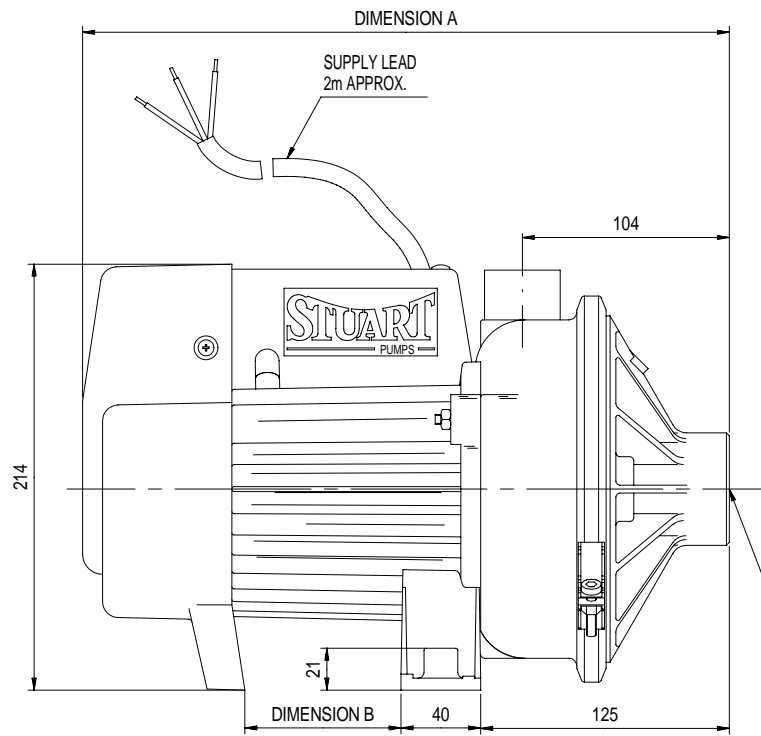
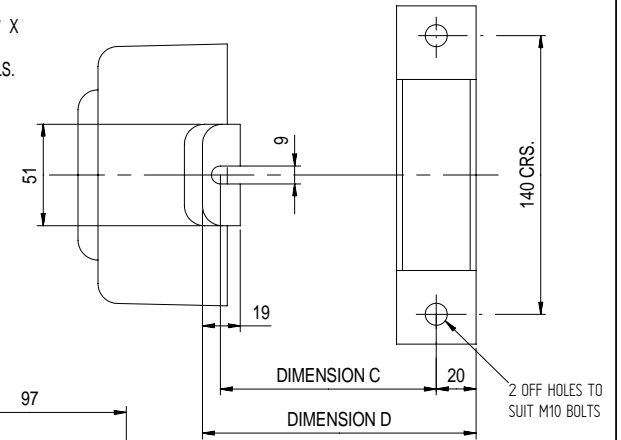

If drawing is to be used for constructional purposes please contact Stuart Turner Ltd and request a certified drawing.

X

Stuart Turner Ltd reserve the right to amend the document or product specifications in line with its policy of continuous development.

Stuart Turner Ltd own the copyright within this document. The document may be printed as much as reasonable for private purposes. The document must not be modified, copied, reproduced, republished or communicated in any other way, without prior written permission from Stuart Turner Ltd, Henley-on-Thames, Oxfordshire, RG9 2AD, England.

GENERAL ARRANGEMENT OF A THAME T6-2 & T12-2

W31425

DATE: 06/12/05